

KNX S4-B12 24 V Actuator for 12/24 V DC drives

Technical specifications and installation instructions

Item number 70533

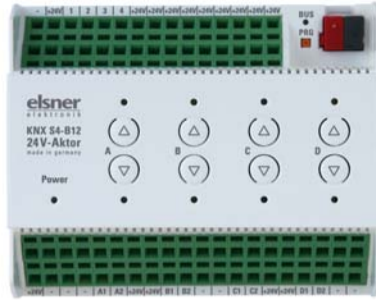

1. Description

The **Actuator KNX S4-B12 24 V** with integrated facade control has 4 outputs for direct current drives (12...24V DC, Up/Down), 4 button pairs and control LEDs. The outputs are compatible with shutter, awning, blind or window drives. Connected drives can be operated directly at **KNX S4-B12 24 V** and via a hand switch.

The automation can be specified externally or internally. Internally, there are numerous options available for blocking, locking (e.g. master-slave) and priority definition (e.g. manual-automatic). Scenes can be saved and called up via the bus (scene control with 16 scenes per drive).

Twelve binary inputs can be used either for direct operation (e.g. hand switches) or as bus switches (or also for e.g. alarm notifications). The desired behaviour can be defined precisely through selection of the response times in Standard, Comfort or Deadman mode.

Functions:

- **4 outputs** with polarity changer for **motors 12...24 V DC** (shading, windows)
- 24V DC internal supply voltage for inputs and for outputs
- Keypad with **4 button pairs** and status LEDs
- **12 binary inputs** for use as hand switches or as bus switches with variable voltage (6...24 V DC)
- **Automatic runtime measurement** of the drives for positioning (including fault notification object)
- **Position feedback** (movement position, also slat position for blinds)
- **Position storage** (movement position) via 1-bit object (storage and call-up e.g. via buttons)
- Control via **internal or external automation**
- Integrated **shade control** for each drive output (with **slat tracking** according to sun position for blinds)
- **Scene control** for movement position with 16 scenes per drive (also slat position for blinds)
- Mutual **locking** of two drives using zero position sensors prevents collisions e.g. of shade and window (master-slave)
- **Blocking objects** and alarm notifications have different **priorities**, so safety functions always take precedence (e.g. wind block)
- **Manual or automatic priority setting** via time or communication object
- **Brief time limit** (movement command blocked) and **2 movement limits**

Configuration is made using the KNX software ETS 5. The **product file** can be downloaded from the ETS online catalogue and the Elsner Elektronik website on www.elsner-elektronik.de in the "Service" menu.

1.0.1. Scope of delivery

- Actuator

1.1. Technical data

Housing	Plastic
Colour	White
Assembly	Series installation on mounting rail
Protection class	IP 20
Dimensions	approx. 107 x 88 x 60 (W x H x D, mm) 6 dividing units
Weight	approx. 300 g
Ambient temperature	Operation -20...+70°C, storage -55...+90°C
Ambient humidity	max. 95% RH, avoid condensation
Operating voltage	24 V DC
Power consumption	typically 5 mA, max. approx. 80 mA
Power	on bus: 10 mA
Outputs	4 x Output with polarity changer for motors 12 V DC/24 V DC (+/-), max. 3A separate power supply for each channel (internal or external voltage)
Minimum current for runtime measurement	DC 150 mA
Inputs	12 x binary inputs, low voltage (6...24 V DC)
Max. cable length	100 m
Binary inputs	
Data output	KNX +/- Bus connector terminal
BCU type	own microcontroller

PEI type	0
Group addresses	max. 1024
Assignments	max. 1024
Communication objects	585

The product conforms with the provisions of EU guidelines.

2. Installation and Commissioning

2.1. Installation notes



Installation, testing, operational start-up and troubleshooting should only be performed by an electrician.



CAUTION! Live voltage!

There are unprotected live components inside the device.

- National legal regulations are to be followed.
- Ensure that all lines to be assembled are free of voltage and take precautions against accidental switching on.
- Do not use the device if it is damaged.
- Take the device or system out of service and secure it against unintentional use, if it can be assumed, that risk-free operation is no longer guaranteed.

The device is only to be used for its intended purpose. Any improper modification or failure to follow the operating instructions voids any and all warranty and guarantee claims.

After unpacking the device, check it immediately for possible mechanical damage. If it has been damaged in transport, inform the supplier immediately.

The device may only be used as a fixed-site installation; that means only when assembled and after conclusion of all installation and operational start-up tasks and only in the surroundings designated for it.

Elsner Elektronik is not liable for any changes in norms and standards which may occur after publication of these operating instructions.

2.2. Connection



Follow the guidelines and standards for SELV electric circuits while installing and cable laying of the KNX connection and the inputs and outputs!

Mixed installation of SELV and non-SELV electrical circuits on the inputs and outputs of the device is not permitted.

2.2.1. Device design

The device is designed for series installation on mounting rails and occupies 6U.

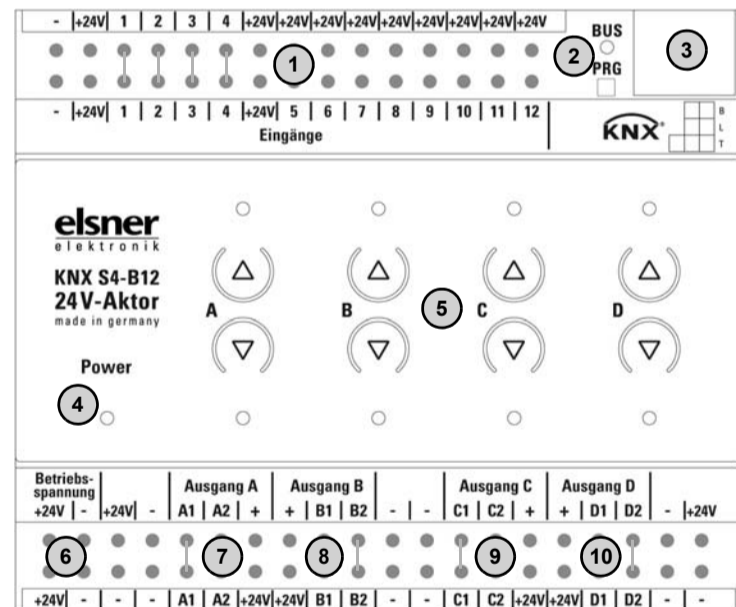

- 1) Binary inputs 1-12 (see also connection example)
- 2) Programming LED and programming buttons (PRG)
- 3) Bus terminal slot (KNX +/-)
- 4) LED "Power", mode display. Siehe "Display of operating status by the power supply LED" auf Seite 1.
- 5) Up/Down button pairs and LEDs channel A-D
- 6) 24 V DC supply voltage input
- 7) Output A "Up"- "Down", max. 3 A
- 8) Output B "Up"- "Down", max. 3 A
- 9) Output C "Up"- "Down", max. 3 A
- 10) Output D "Up"- "Down", max. 3 A

All +24 V terminals and the top terminal strip are bridged internally.

All +24 V terminals and the bottom terminal strip are bridged internally.

2.2.2. Display of operating status by the power supply LED

Behaviour	Colour	
On	Green	Normal operation. Bus connection/bus voltage available.

Behaviour	Colour	
Flashes	Green	Normal operation. No bus connection/bus voltage available.
On	Orange	Device starts up or is being programmed via the ETS. No automatic functions are executed.
Flashes	Green (on), Orange (flashing)	Programming mode active.

2.2.3. Status display by the channel LEDs

Behaviour	LED	
To	top	Drive in top end position/device on.
To	bottom	Drive in bottom end position/drive on.
Flashes slowly	top	Drive moves up.
Flashes slowly	bottom	Drive moves down.
Flashes quickly	top	Drive in top end position, barrier active.
Flashes quickly	bottom	Drive in bottom position, barrier active.
Flashes quickly	both simultaneously	Drive in intermediate position, barrier active.
Extend	both	Drive in intermediate position.
Flashes	both alternately	Automatic runtime determination error. If the drive can be moved, drive it into the end position by hand (drive in/drive out completely or open/close) in order to restart the runtime determination. If the drive cannot be moved, check the connections.
"Runlight" above all LEDs	all channels	Incorrect application version was loaded. Use the version compatible with the device!

2.3. Notes on mounting and commissioning

Device must not be exposed to water (rain). This could result in the electronics being damaged. A relative air humidity of 95% must not be exceeded. Avoid condensation.

After the operating voltage has been applied, the device will enter an initialisation phase lasting a few seconds. During this phase no information can be received or sent via the bus.

For KNX devices with safety functions (e.g. wind or rain blocks), periodical monitoring of the safety objects must be set up. The optimal ratio is 1:3 (example: if the weather station sends a value every 5 minutes, the actuator must be configured for a monitoring period of 15 minutes).

2.4. Connection examples

Use of binary input No. 1 with external auxiliary voltage (6...24 V DC)

Use of binary input No. 12 with internal auxiliary voltage (24 V DC)

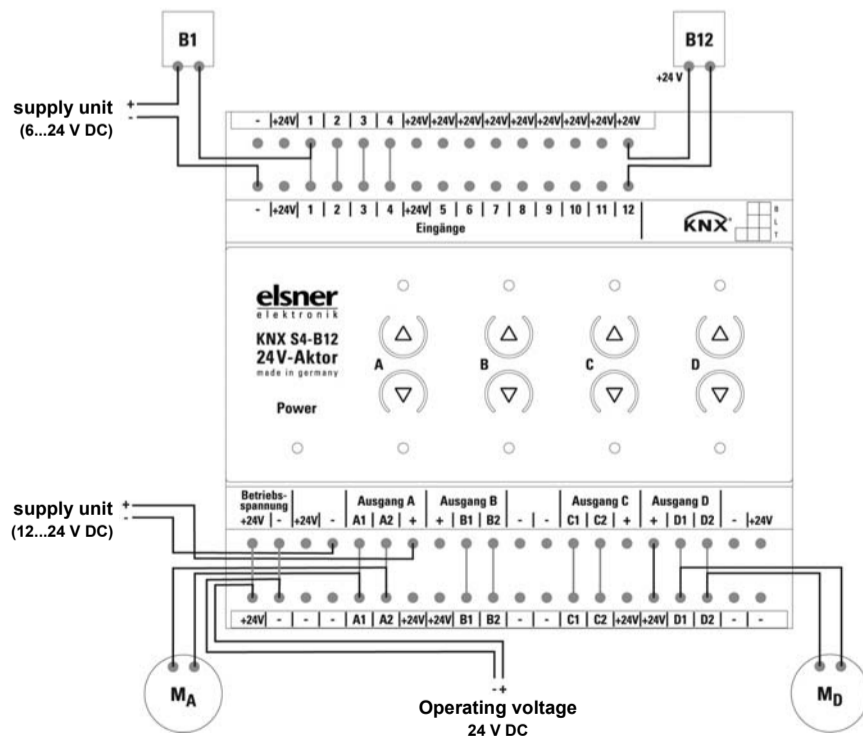

Use of drive output A with external auxiliary voltage (12...24 V DC)

Use of drive output D with internal auxiliary voltage (24 V DC). The +24 V internal voltage must be bridged to the + terminal of output D for this.