

KNX S1R-B4 compact Multifunctional Actuator

Technical specifications and installation instructions

Item number 70550

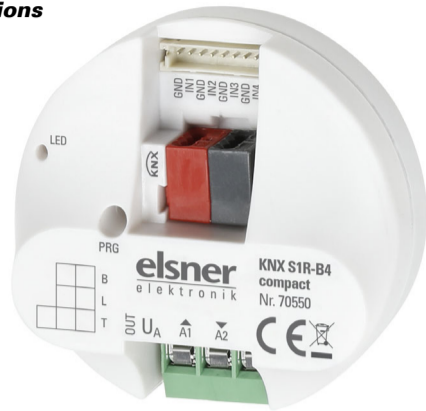

1. Description

The **Actuator KNX S1R-B4 compact** with integrated façade control has got a multifunctional output which can connect to either a drive with Up/Down control (blinds, awnings, shutters, windows) or two switchable devices (On/Off for light and ventilation). Because the output is designed to be free of potential, other systems can also be controlled, e.g. via the manual switch input on a motor control unit.

Automation can be specified externally or internally. Internally, there are numerous options available for blocking, locking (e.g. master-slave) and priority definitions (e.g. manual-automatic). Scenes can be saved and called up via the bus (scene control with 16 scenes).

4 digital inputs are available for the connection of binary contacts. A zero position sensor or push-button, for example, can be connected here.

Functions:

- **Free of potential multifunctional output for a 230 V drive** (shading, windows) or connection of two **switchable devices** (light, fan)
- **4 binary inputs**
- **Position feedback** (movement position, also slat position for shutters)
- **Position storage** (movement position) via 1-bit object (storage and call-up e.g. via buttons)
- Parameters for taking drive and mechanics **downtimes** into account
- Control via **internal or external automation functions**
- Integrated **shade control** with **slat adjustment** for shutters based on the position of the sun
- **Scene control** for movement position with 16 scenes (also slat position for shutters)
- Mutual locking of two drives using **zero position sensors** prevents collisions e.g. of shade and window (master-slave)
- **Blocking objects and alarm reports** have different priorities, so safety functions always take precedence (e.g. wind block)
- Manual or automatic **priority** setting via time or communication object
- **Brief time limit** (movement command blocked) and **2 movement limits**

Configuration is made using the KNX software ETS 5. The **product file** can be downloaded from the ETS online catalogue and the Elsner Elektronik website on www.elsner-elektronik.de in the "Service" menu.

1.0.1. Scope of delivery

- Actuator
- Connection line for inputs

1.1. Technical specification

Housing	Plastic
Colour	White
Assembly	Flush-mounted (in connector socket Ø 60 mm, 60 mm deep)
Protection category	IP 20
Dimensions	Ø approx. 52 mm, depth approx. 24 mm
Weight	approx. 40 g
Ambient temperature	Operation -20...+70°C, storage -30...+85°C
Ambient humidity	5...80% RH, non-condensing
Operating voltage	KNX bus voltage
Current at the bus	relays not energised: 15 mA 2 relays energised: 18 mA
Output	1 × output, free of potential with 2 connections for drive up/down or 2 devices, power supply U up (A1) down (A2) Output load capacity: 5 A, maximum 270 V AC/30 V DC
Inputs	4× digital, maximum cable length 10 m
Data output	KNX +/- bus connector terminal
BCU type	Integrated microcontroller
PEI type	0
Group addresses	max. 254
Assignments	max. 254
Communication objects	156

The product is compliant with the provisions of EU guidelines.

2. Installation and start-up

2.1. Installation notes



Installation, testing, operational start-up and troubleshooting should only be performed by an electrician.



DANGER!

Risk to life from live voltage (mains voltage)!

There are unprotected live components within the device.

- VDE regulations and national regulations are to be followed.
- Ensure that all lines to be assembled are free of voltage and take precautions against accidental switching on.
- Do not use the device if it is damaged.
- Take the device or system out of service and secure it against unintentional use, if it can be assumed, that risk-free operation is no longer guaranteed.

The device is only to be used for its intended purpose. Any improper modification or failure to follow the operating instructions voids any and all warranty and guarantee claims.

After unpacking the device, check it immediately for possible mechanical damage. If it has been damaged in transport, inform the supplier immediately.

The device may only be used as a fixed-site installation; that means only when assembled and after conclusion of all installation and operational start-up tasks and only in the surroundings designated for it.

Elsner Elektronik is not liable for any changes in norms and standards which may occur after publication of these operating instructions.

2.2. Connection

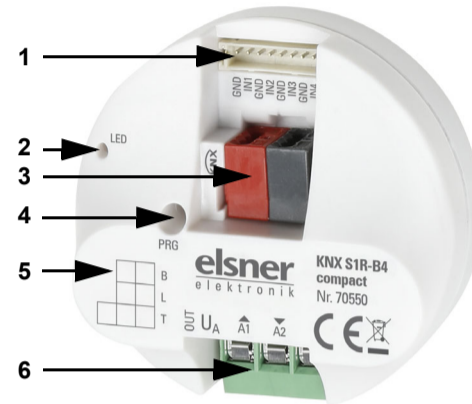

Fig. 1

- 1 Digital inputs: Slot for connection cable
- 2 Programming LED (recessed)
- 3 KNX plug connector +/-
- 4 Programming button (recessed)
- 5 Labeling field
- 6 Connector for drive/consumers (free of potential),
U_A: voltage, maximum 270 V AC
up/A1: motor upwards or consumer 1 switching
down/A2: motor downwards or consumer 2 switching

The **Actuator KNX S1R-B4 compact** is installed in a flush-mounted socket. The connection is made using a KNX connector on the KNX data bus. In addition, a power supply for the connected drive or consumer is necessary (output free of potential).



Follow the guidelines and standards for SELV electric circuits while installing and cable laying of the KNX connection and inputs!

The physical address is assigned by the KNX software. There is a button with a control LED for this on the actuator.

To connect the digital inputs (fig. 1 no. 1) use the attached breakout cable. The cables for the inputs can be extended to up to 10 m. All GND connections of the inputs are bridged internally (black cable).

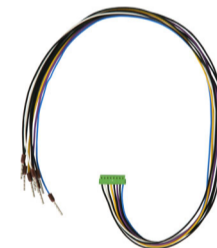
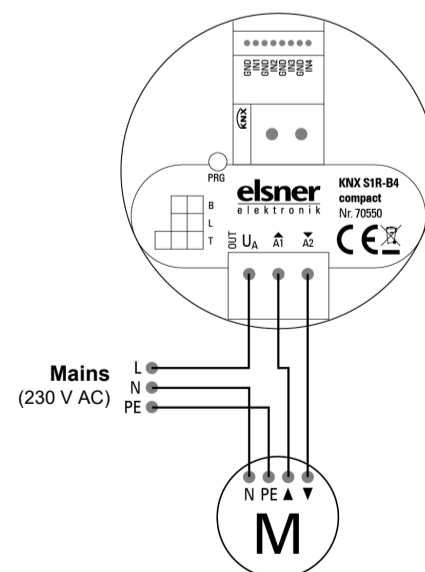

Fig. 2

Breakout cable for digital inputs:
Input 1: black (GND) / white
Input 2: black (GND) / yellow
Input 3: black (GND) / violet
Input 4: black (GND) / blue

2.2.1. Connection examples output

Drive 230 V AC:



Two consumer loads 230 V AC:

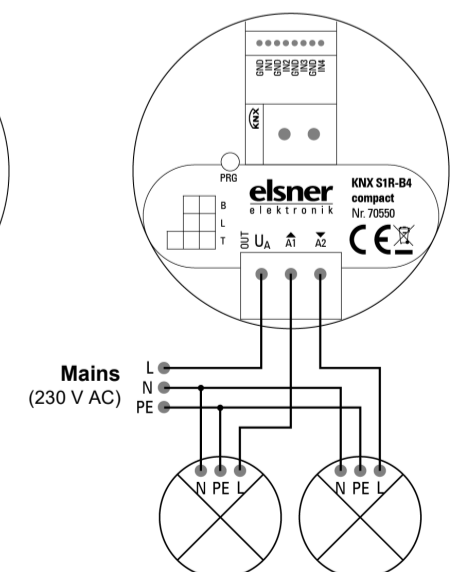

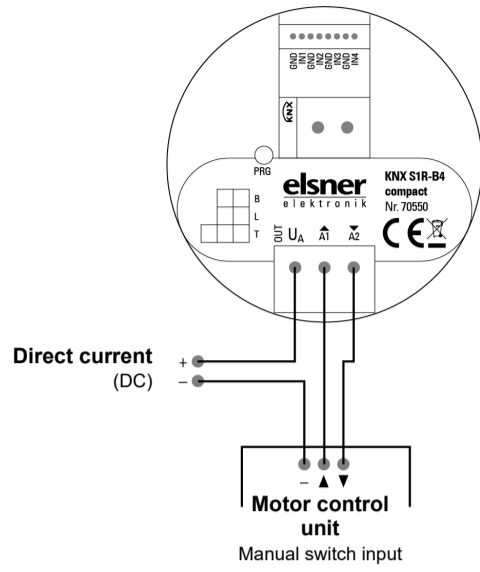
Control of an external motor control unit with 24 V DC:**2.3. Instructions for assembly and operational start-up.**

Never expose actuators to water (e.g. rain) or dust. This can damage the electronics. You must not exceed a relative air humidity of 80%. Avoid condensation.

After the auxiliary voltage has been applied, the device will enter an initialisation phase lasting a few seconds. During this phase no information can be received or sent via the bus.

For KNX devices with safety functions (e.g. wind or rain blocks), it is important to set up periodical monitoring of the safety objects. The optimal ratio is 1:3 (example: if the weather station sends a value every 5 minutes, the actuator must be configured for a monitoring period of 15 minutes).

3. Addressing of the device at the bus

The device is supplied with the bus address 15.15.255. You can program another address into the ETS by overwriting the 15.15.255 address or by teaching via the programming button.