

Cala KNX T 101

Room Temperature Controller

Technical specifications and installation instructions

Item numbers 70980 (white), 70982 (black)



1. Description

The **Room Temperature Controller Cala KNX T 101** measures the room temperature and displays the current value. Via the bus the device can receive an external measured value and process it with own data to overall temperature value (mixed value).

The **Cala KNX T 101** has got an integrated PI controller for a heating and a cooling system (one or two step). The room temperature is adjusted by means of the „+“ and „-“ touch buttons.

The device is supplemented with a frame of the switch series used in the building, and thus fits seamlessly into the interior fittings.

Functions:

- Measurement of **temperature. Mixed value** from own measured value and external values (proportions can be set in percentage), output of minimum and maximum values
- **Display** of the actual value or the target value/basic setpoint shift
- **2 touch buttons** (+/-) for adjustment of the room temperature
- **PI controller for heating** (one or two step) and **cooling** (one or two step) depending on temperature. Control according to separate target values or basic target temperature

Configuration is made using the KNX software ETS 5. The **product file** can be downloaded from the ETS online catalogue and the Elsner Elektronik website on www.elsner-elektronik.de in the "Service" menu.

1.0.1. Scope of delivery

- Room temperature controller in casing
 - Base plate
- Additionally required (not included in the deliverables):*
- Junction box Ø 60 mm, 42 mm deep
 - Frame (for insert 55 x 55 mm), compatible to the switch scheme used in the building

1.1. Technical data

Casing	Genuine glass, plastic
Colours	<ul style="list-style-type: none"> • similar to RAL 9010 pure white • similar to RAL 9005 deep black
Installation	Flush-mounted (wall installation in junction box Ø 60 mm, 42 mm deep or cavity wall socket for burr hole Ø 68 mm)
IP rating	IP 20
Dimensions	Housing approx. 55 x 55 (W x H, mm), Installation depth approx. 10 mm, Base plate approx. 71 x 71 (W x H, mm)
Total weight	approx. 50 g
Ambient temperature	Operating 0...+55°C, storage -30...+85°C
Ambient humidity	5...95% RH, avoid condensation
Operating voltage	KNX bus voltage
Bus current	max. 15 mA
Data output	KNX +/- Bus plug-in terminal
BCU type	Own microcontroller
PEI type	0
Group addresses	max. 183
Allocations	max. 183
Communication objects	41
Temperature measurement range	0...+55°C
Temperature resolution	0.1°C

The product is compliant with the provisions of EU Directives.

1.1.1. Accuracy of the measurement

Measurement variations from permanent sources of interference (see chapter *Installation position*) can be corrected in the ETS in order to ensure the specified accuracy of the sensor (offset).

When **measuring temperature**, the self-heating of the device is compensated.

2. Installation and commissioning

2.1. Installation notes



Installation, testing, operational start-up and troubleshooting should only be performed by an electrician.



CAUTION! Live voltage!

There are unprotected live components inside the device.

- National legal regulations are to be followed.
- Ensure that all lines to be assembled are free of voltage and take precautions against accidental switching on.
- Do not use the device if it is damaged.
- Take the device or system out of service and secure it against unintentional use, if it can be assumed, that risk-free operation is no longer guaranteed.

The device is only to be used for the intended purpose described in this manual. Any improper modification or failure to follow the operating instructions voids any and all warranty and guarantee claims.

After unpacking the device, check it immediately for possible mechanical damage. If it has been damaged in transport, inform the supplier immediately.

The device may only be used as a fixed-site installation; that means only when assembled and after conclusion of all installation and operational start-up tasks and only in the surroundings designated for it.

Elsner Elektronik is not liable for any changes in norms and standards which may occur after publication of these operating instructions.

2.2. Installation position

The **Room Temperature Controller Cala KNX T 101** is designed for wall installation in a connector socket (Ø 60 mm, 42 mm deep).

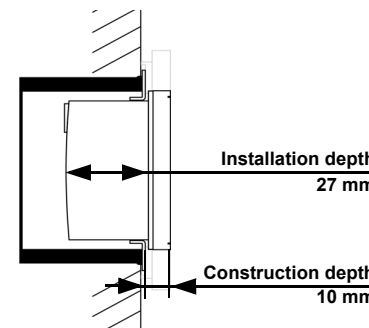

Fig. 1: Sectional drawing.

The **Room Temperature Controller Cala KNX T 101** fits in a standard connector socket (Ø 60 mm, depth 42 mm). The frame is not included in the delivery!



May be installed and operated in dry interior rooms only. Avoid condensation.

When selecting an installation location, please ensure that the measurement results are affected as little as possible by external influences. Possible sources of interference include:

- Direct sunlight
- Drafts from windows and doors
- Draft from ducts which lead from other rooms or from the outside to the junction box in which the sensor is mounted
- Warming or cooling of the building structure on which the sensor is mounted, e.g. due to sunlight, heating or cold water pipes
- Connection lines and ducts which lead from warmer or colder areas to the sensor

Measurement variations from permanent sources of interference can be corrected in the ETS in order to ensure the specified accuracy of the sensor (offset).

2.3. Device structure

2.3.1. Casing

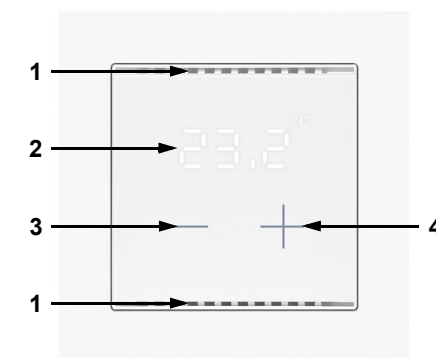

Fig. 2: Front

- 1 Ventilation slit (top and bottom)
- 2 Temperatur display
- 3 Touch area -
- 4 Touch area +

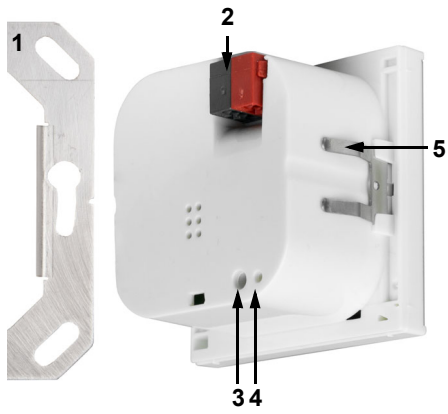

Fig. 3: Back
1 Base frame
2 KNX terminal BUS +/-
3 Programming button (recessed) for teaching the device
4 Programming LED (recessed)
5 Catches

2.4. Installation of the sensor

First install the windproof socket with feed line. Seal the inlet tubes as well, in order to prevent draughts. Then screw the base plate to the socket and place the switch program frame. Connect the bus cable +/- to the plug (black-red). Insert the device firmly onto the metal frame using the catches so that the device and the housing are fixed together.

2.5. Notes on mounting and commissioning

Never expose the device to water (e.g. rain) or dust. This can damage the electronics. You must not exceed a relative humidity of 95%. Avoid condensation.

After the bus voltage has been applied, the device will enter an initialisation phase lasting a few seconds. During this phase no information can be received or sent via the bus.

3. Addressing of the device at the bus

The device is supplied with the bus address 15.15.255. You can program another address into the ETS by overwriting the 15.15.255 address or by teaching via the programming button.

4. Display and operation at the device

4.1. Adjust room temperature

Depending on the setting of the "Display mode" parameter in the device application, the **Room Temperature Controller Cala KNX T 101** displays the current room temperature value (or mixed value), the target value or the shift in relation to the basic setpoint. The display can be dimmed and switched off via the bus so that *no* value is displayed.

Option A: Display of actual temperature (room temperature)

The current room temperature is displayed. It is *not* possible to change the room temperature manually using the +/- buttons.

Option B: Display of target temperature or basic setpoint shift

Depending on the setting, the current target value or the shift relative to the base setpoint is displayed. The temperature can be changed by touching the +/- buttons.

Target value display (absolute value):

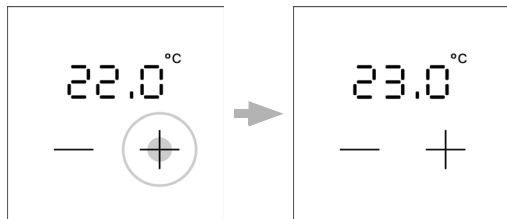

Tap +:
Increase room temperature
(target temperature is increased)

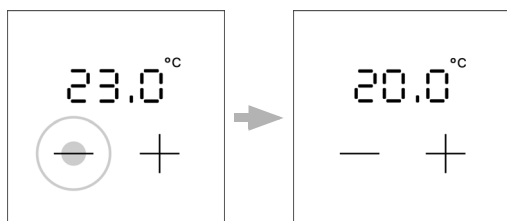

Tap -:
Lower room temperature
(target temperature is lowered)

Display of the **basic setpoint shift** (change compared to the basic setpoint of the control):

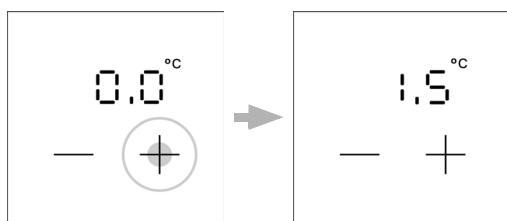

Tap +:
Increase room temperature
(Basic setpoint shift direction PLUS)

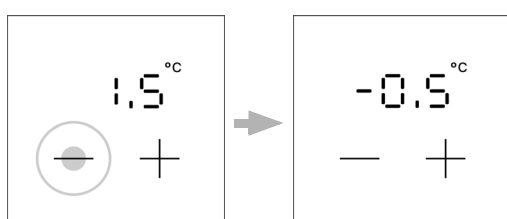

Tap -:
Lower room temperature
(Basic setpoint shift direction MINUS)

Option C: Display of actual temperature and target temperature/basic setpoint shift

During normal operation, the current room temperature is displayed. By touching the buttons, the display jumps to the target temperature or to the basic setpoint shift, depending on the presetting. Changes with + or - are visible. The display returns to the room temperature if no button is touched for 7 seconds.

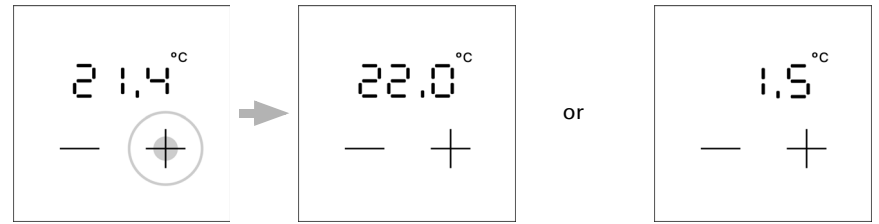

Touch the **+** or **-** button briefly: The current **target temperature** (or the basic setpoint shift) is displayed.

Tap +: Increase room temperature
(target temperature/basic setpoint shift is increased).

Tap -: Lower room temperature
(target temperature/basic setpoint shift is lowered).

General:

The step size for the change and the possible setting range are defined in the device application (ETS). There you can also define whether the manually changed values are retained after a mode change (e.g. Eco mode overnight) or reset to the stored values.

The button functions can be locked due to operating mode with priority 1.

5. Maintenance

Ventilation slits must not be dirty or covered. As a rule, it is sufficient to wipe the device with a soft, dry cloth as required.

6. Disposal

After use, the device must be disposed of or recycled in accordance with the legal regulations. Do not dispose of it with the household waste!