

FEATURES

- Customizable printed glass with 5 touch areas with backlight
- Available in the following colors: silver (RAL 9006), anthracite black (RAL 9004) and white (RAL 9016)
- 2.4" OLED display (128x64 pixels)
- 2 analog/digital inputs
- Thermostat
- Clock functionality (subject to updating through devices with RTC or NTP client)
- Built-in temperature, humidity, luminosity and proximity sensors
- Total data saving on KNX bus failure
- Integrated KNX BCU (TP1-256)
- Dimensions 82.1 x 82.1 x 33.2 mm (9 mm outside the wall)
- Flush mount on back box
- Conformity with the CE, UKCA, RCM directives (marks on the back side)

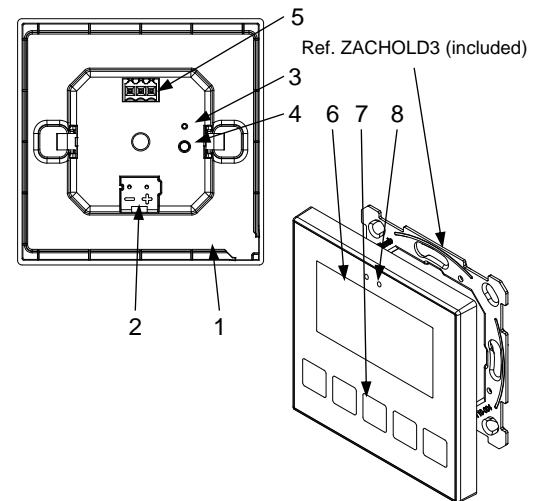

Figure 1: Flat Display v2

1. Temperature and humidity sensor	2. KNX connector	3. Programming LED	4. Programming button
5. Inputs connector	6. Display	7. Touch area	8. Luminosity and proximity sensor

Programming button: short press to set programming mode. If this button is held while plugging the device into the KNX bus, it enters the safe mode.

Programming LED: programming mode indicator (red). When the device enters the safe mode, it blinks (red) every half second. During the start-up (reset or after KNX bus failure) and if the device is not in safe mode, it emits a red flash.

GENERAL SPECIFICATIONS

CONCEPT		DESCRIPTION		
Type of device		Electric operation control device		
KNX supply	Voltage (typical)	29 VDC SELV		
	Voltage range	21-31 VDC		
	Maximum consumption	Voltage	mA	mW
		29 VDC (typical)	17.5	507.5
24 VDC ¹	22.5	540		
Connection type		Typical TP1 bus connector for 0.8 mm Ø rigid cable		
External power supply		Not required		
Operation temperature		0 .. +55 °C		
Storage temperature		-20 .. +55 °C		
Operation humidity		5 .. 95%		
Storage humidity		5 .. 95%		
Complementary characteristics		Class B		
Protection class		III		
Operation type		Continuous operation		
Device action type		Type 1		
Electrical stress period		Long		
Degree of protection		IP20, clean environment		
Installation		Flush mount on back box		
Minimum clearances		Not required		
Response on KNX bus failure		Data saving according to parameterization		
Response on KNX bus restart		Data recovery according to parameterization		
Operation indicator		The programming LED indicates programming mode (red). Backlighting of touch areas and display depending on their / the parameterization.		
Weight		91 g		
Housing material		PC+ABS FR V0 halogen free		

¹ Maximum consumption in the worst-case scenario (KNX Fan-In model).

INPUTS SPECIFICATIONS AND CONNECTIONS	
CONCEPT	DESCRIPTION
Number of inputs	2
Inputs per common	2
Operation voltage	+3.3 VDC in the common
Operation current	1 mA @ 3.3 VDC (per input)
Switching type	Dry voltage contacts between input and common
Connection method	Pluggable screw terminal block (0.2 Nm max.)
Cable cross-section	0.2-1.5 mm ² (IEC) / 28-14 AWG (UL)
Maximum cable length	30 m
NTC accuracy (@ 25 °C) ²	±0.5 °C
Temperature resolution	0.1 °C
Maximum response time	10 ms

² For Zennio temperature probes.

TEMPERATURE AND HUMIDITY SENSOR SPECIFICATIONS	
CONCEPT	DESCRIPTION
Temperature measurement range	-40 .. 90 °C
Temperature resolution / accuracy ³	0.1 °C / ±0.5 °C (@ 25 °C)
Humidity measurement range	0 .. 100% RH
Humidity response time	1s
Humidity resolution / accuracy	1% / ±5% RH
Humidity drift	±0.25% RH per year in normal air

³ The accuracy of the sensor may be reduced in case of keeping the backlight status LEDs permanently on.

INPUTS CONNECTION

Any combination of the following accessories is allowed in the inputs:

Temperature Probe**

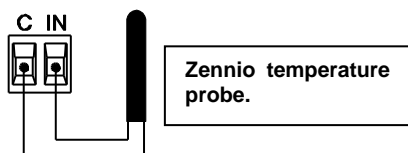

Motion Sensor

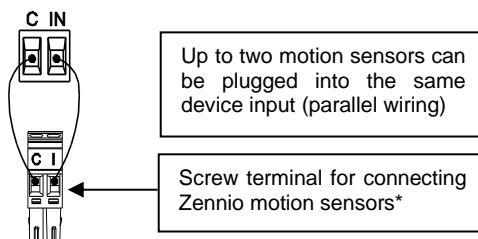

Switch/Sensor/ Push button

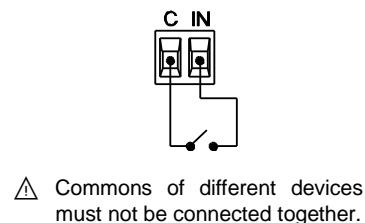

* In case of using ZN1IO-DETEC-P sensor, its micro switch number 2 must be in **Type B position**.

** Zennio temperature probe or any NTC with known resistance values at three points in the range [-55, 150 °C].

INSTALLATION INSTRUCTIONS

1. Fix the metal plate into a square or round back box by using the screws from the box, checking that it is levelled.
2. Connect the KNX bus and the inputs terminal to the back of the device.
3. Fit the device into its final position and check that the strength of the clips is enough to fix the device. Avoid pressing on the display during this step, in order to prevent accidental damages to the device.

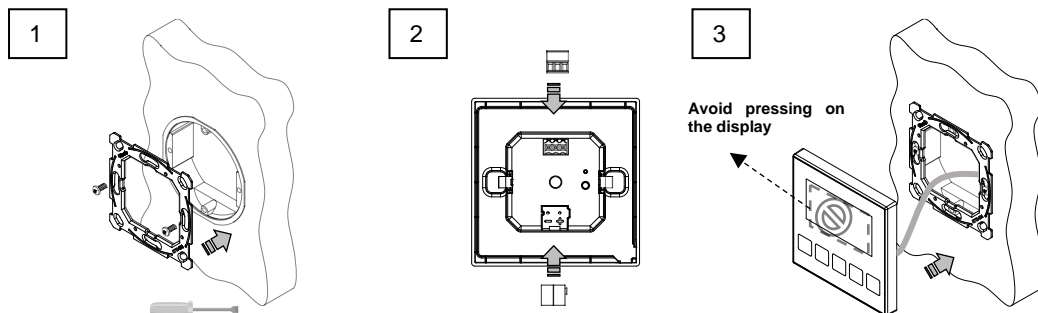

⚠ IMPORTANT:

For a correct temperature and humidity measurement, the mounting location must not be exposed to airflows or direct sun radiation.

DIMENSIONS (mm)

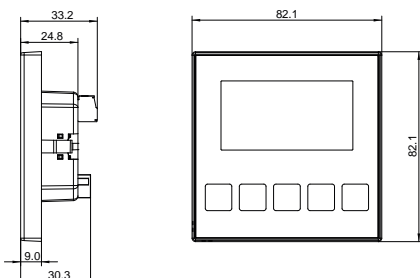

⚠ SAFETY INSTRUCTIONS AND ADDITIONAL NOTES

- Installation should only be performed by qualified professionals according to the laws and regulations applicable in each country.
- Do not connect the mains voltage nor any other external voltage to any point of the KNX bus; it would represent a risk for the entire KNX system. The facility must have enough insulation between the mains (or auxiliary) voltage and the KNX bus or the wires of other accessories, in case of being installed.
- Keep the device away from water (condensation over the device included) and do not cover it with clothes, paper or any other material while in use.
- In order to improve the lifespan of the LED indicators, parameterising constant lighting is not recommended.
- The WEEE logo means that this device contains electronic parts and it must be properly disposed of by following the instructions at <https://www.zennio.com/en/legal/wEEE-regulation>.
- This device contains software subject to specific licences. For details, please refer to <https://zennio.com/licenses>.