

20 A8 Binary with status 900701

Use of the application program

Product family: Output
 Product type: Load switch, 8-fold
 Manufacturer: Siemens

Name: Load switch N 512
 Order no.: 5WG1 512-1AB01

Functional description

The application program "20 A8 Binary with status 900701" is used for carrying out the switch functions of the 8-fold load switch N 512. By assigning parameters, it is possible to define whether all 8 channels are controlled independently or whether 3 channels or 2 times 3 channels are combined and controlled simultaneously by the application program. Each channel has a communication object available for switching, status interrogation and logic operations. It is also possible to assign the following parameters for each channel:

- Logic operation
- Starting value of switching object / logic operation on bus voltage recovery
- On delay
- Off delay
- Relay mode: normally open/normally closed contact
- Operating mode: normal mode/time switch
- Behaviour on bus voltage failure (independent of the logic object)
- Send status object: read only / on change in object value.

All the above parameters are available for a group of 3 channels (channels A,B,C and/or channels E,F,G) for carrying out applications that require simultaneous switching.

Maximum number of group addresses: 52
 Maximum number of associations: 52

Block diagram of a channel

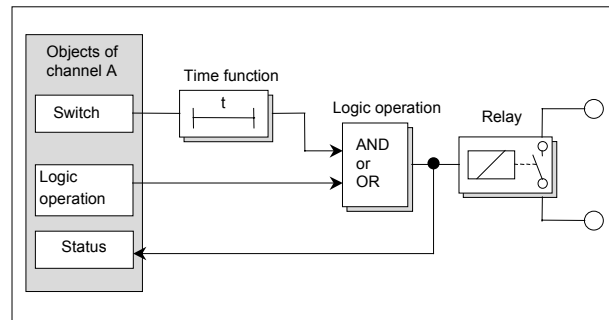

Communication objects

The following communication objects are available for each channel or each group of 3 channels.

Phys. Addr.		Program		
no.	Function	Object name	Type	
----- 20 A8 Binary with status 900701				
0	Switch	Channel A	1 Bit	
1	Status	Channel A	1 Bit	
2	Logic operation	Channel A	1 Bit	
---	---	---	---	

Note

The view of the objects can be arranged individually i.e. this view can vary.

Obj	Function	Object name	Type	Flag
0	Switch	Channel A	1 Bit	CW
The switching telegrams that are relayed via the time function to the relay channel are received via the group addresses in this object. If a logic operation is assigned, the result of the time function forms the first value of the logic operation for the channel.				
1	Status	Channel A	1 Bit	CRT
The current switching status of the channel is stored in the status object and can be checked by a read request. Parameters can be assigned so that the status is sent automatically after each change in the object value.				
2	Logic operation	Channel A	1 Bit	CW
The switching information for the second input of the logic operation is received via the group addresses in this object. If the setting "no logic operation" is selected, this object has no function and is not displayed.				

20 A8 Binary with status 900701

Parameters

Configuration:



Parameters	Settings
Switch several channels with equal function	disabled Channels A,B,C Channels A,B,C and Channels E,F,G
Using this parameter, Channels A,B,C and E,F,G can be combined into a group of 3 Channels to carry out simultaneous switch functions. The settings are made in a parameter window.	

Parameters of a channel:

The following parameters are available for each channel (A - H) or for each group of 3 channels.

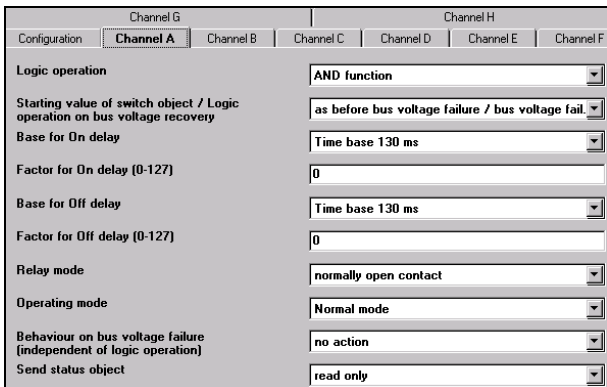

Parameters	Settings
Logic operation	no logic operation OR function AND function
Using this parameter, a logic operation can be carried out between the switching object and the logic object. The telegrams of the switching object reach the first input of the logic operation. They are executed with an On or an Off delay according to the parameters assigned. The second input is linked with the logic object. The logic object is not subject to a time function and therefore the logic operation is carried out immediately. "no logic operation": The telegram information of the switching object is routed to the relay without a logic operation but with a set On or Off delay. The logic object has no function.	

Parameters	Settings
"OR function": The switching and logic objects are linked with an OR function. "AND function": The switching and logic objects are linked with an AND function.	
Starting value of switch object / Logic operation on bus voltage recovery	as before bus voltage failure / as before bus voltage failure as before bus voltage failure / Off as before bus voltage failure / On Off / as before bus voltage failure Off / Off Off / On On / as before bus voltage failure On / Off On / On
The initialisation value of the switching and logic object on bus voltage recovery is defined here. If the setting "no logic operation" is selected in the parameter "Logic operation", the parameter changes to "Starting value of the switching object".	
Starting value of the switching object	as before bus voltage failure Off On
This parameter defines the initialisation value for the switch object on bus voltage recovery when no logic operation has been defined. Caution: After a download, the preassigned option for "as before bus voltage failure" = 0 i.e. "Off".	
Base for On delay	Time base 130 ms Time base 260 ms Time base 520 ms Time base 1 sec Time base 2.1 sec Time base 4.2 sec Time base 8.4 sec Time base 17 sec Time base 34 sec Time base 1.1 min Time base 2.2 min Time base 4.5 min Time base 9 min Time base 18 min Time base 35 min Time base 1.2 hr
Factor for On delay (0-127)	0
These parameters are used to set the time for the On delay. It is calculated from the selected base multiplied by the factor that is entered here. Factor = "0": There is no active On delay. A logic "1" that is passed to the time function is routed without a delay. Note: An attempt should always be made to set the required time with the smallest possible base as the base that is set here also specifies the maximum timing error.	

20 A8 Binary with status 900701

Parameters	Settings
Base for Off delay	Time base 130 ms Time base 260 ms Time base 520 ms Time base 1 sec Time base 2.1 sec Time base 4.2 sec Time base 8.4 sec Time base 17 sec Time base 34 sec Time base 1.1 min Time base 2.2 min Time base 4.5 min Time base 9 min Time base 18 min Time base 35 min Time base 1.2 hr
Factor for Off delay (0-127)	0
These parameters are used to set the time for the Off delay. It is calculated from the selected base multiplied by the factor that is entered here. Factor = "0": There is no active Off delay. A logic "0" that is passed to the time function is routed without a delay. Note: An attempt should always be made to set the required time with the smallest possible base as the base that is set here also specifies the maximum timing error.	
Relay mode	normally open contact normally closed contact
This parameter defines the behaviour of the relay contact. If the setting "normally closed contact" is selected, switching off always closes the contact and switching on always opens the contact. "normally open contact": Off telegram = contact open, On telegram = contact closed. "normally closed contact": Off telegram = contact closed, On telegram = contact open.	
Operating mode	Normal mode Time switch
The operating mode of the Off delay is set here: "Normal mode": When an Off telegram is received via the switching object, the set Off delay is started. Each further "0" that is received before the timer has elapsed, resets the delay and restarts it. Once the period has elapsed, the "0" is passed to the output. An On telegram removes the Off delay. "Time switch": When an On telegram is received via the switching object, it is routed directly to the output. The set Off delay starts simultaneously. Any On delay that has been set has no effect. Each further "1" that is received before the timer has elapsed, resets the delay and restarts it. Once the period has elapsed, the "1" delay is passed to the output. An Off telegram removes the Off delay and is immediately routed to the output. (see also "Timing diagrams").	

Parameters	Settings
Behaviour on bus voltage failure (independent of logic operation)	no action Off On
The behaviour of the relay contact on bus voltage failure can be set here. The setting only refers to the switching object and is independent of the logic object. The behaviour on download is divided into two phases: First of all the relay assumes the position which is assigned in the parameter "Behaviour on bus voltage failure". If the setting "no action" is selected, the relay remains idle. A few seconds later however the parameter setting "Starting value of switch object" takes effect. There is the optional of selecting "On", "Off" or "as before bus voltage failure". The setting "as before bus voltage failure" is not interpreted as neutral (no action) after a download but as "Off" and the command is carried out (see note above). Otherwise the relays assume the position which was defined in the parameter "Starting value of switch object", even after a download.	
Send status object	read only on change object value
Depending on the parameter setting, the status object is sent automatically after each change in the object value or only after a read request.	

Examples of timing diagrams for channels

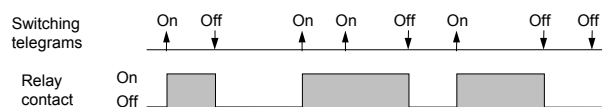
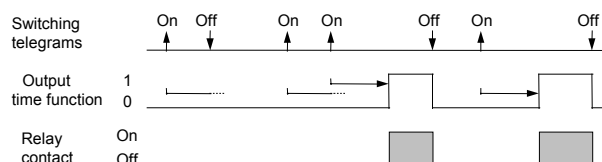
**1. Switching without a time delay,
 no logic operation,
 relay mode: normally open contact**

**2. Switching with an On delay,
 no logic operation,
 relay mode: normally open contact**

20 A8 Binary with status 900701

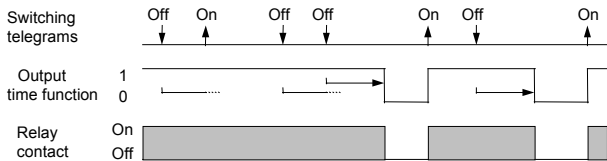
3. Switching with an Off delay, no logic operation, relay mode: normally open contact

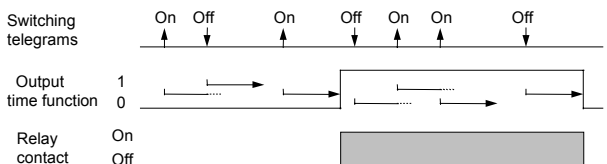

4. Switching with an On and Off delay, no logic operation, relay mode: normally open contact



5. Switching with time switch function, no logic operation, no On delay, relay mode: normally open contact

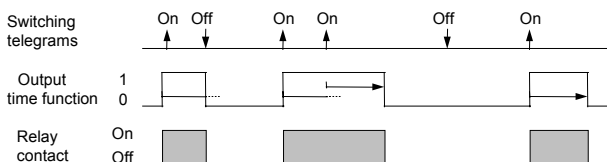

6. Switching with AND function, no time delays, relay mode: normally open contact

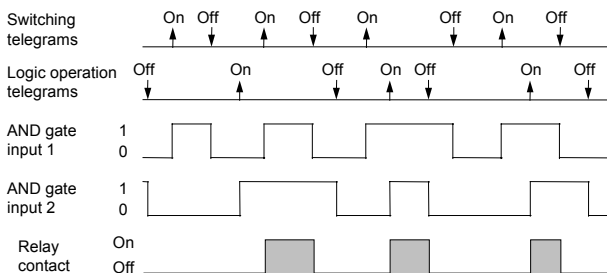

7. Switching with OR function, with an On delay, relay mode: normally open contact

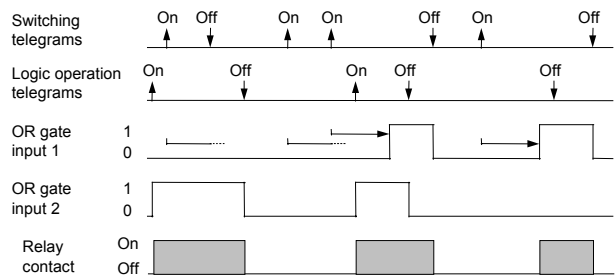

8. Switching with AND function, with On and Off delay, relay mode: normally open contact

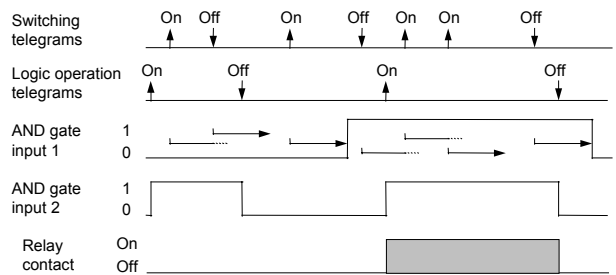

9. Switching with OR function and time switch function, relay mode: normally open contact

