

KNX manual

Actuator

KNX Electromotor Valve Control



KNX Electromotor Valve Control 57002

Contents

1	Function description	3
2	Technical data	4
3	General information about KNX Secure	5
3.1	Start-up with "KNX Data Secure"	6
3.2	Start-up without "KNX Data Secure"	6
4	The KNX Electromotor Valve Control application programme	7
4.1	Selection in the product database	7
4.2	Overview of communication objects	8
4.3	Description of communication objects	14
4.4	Parameter pages overview	26
4.5	General parameters	27
4.6	Parameters for the heating controller	29
4.7	Parameters for the actuator	49
4.8	Parameters for external inputs I1, I2	58
5	Start-up	76
5.1	Connection	76
5.2	Installation	77
5.3	Installation and automatic adjustment (calibration traverse)	78
5.4	Calibration strategies	79
5.5	Site function	80
5.6	Valves and valve seals	81
6	Appendix	82
6.1	Determining the current operating mode	82
6.2	Priorities for operating mode selection	83
6.3	Base setpoint and current setpoint	84
6.4	Determination of the setpoint	85
6.5	Setpoint offset	87
6.6	Dead zone	87
6.7	Valve protection	88
6.8	Determining the highest actuating value	88
6.9	Restriction of actuating value	91
6.10	PWM cycle	92
6.11	Setpoint calculation	94

1 Function description

- Electromotive KNX actuator
- Integrated controller for heating and cooling with one additional stage each
- Universally usable binary inputs
- Integrated temperature sensor
- Automatic valve adaptation
- Universally compatible due to large range of valve adapters
- Integrated logic for up to 10 window contacts

2 Technical data

Operating voltage	KNX bus voltage
KNX bus current	7.5 mA
Connection type	Line with KNX bus terminal
L x W x D	80 x 50 x 64 mm
Ambient temperature	5 °C ... +50 °C
Temperature measurement range	Internal sensor: 0 °C to +60 °C External sensor at I2: 0 °C to +60 °C
Runtime	< 20 s/mm
Maximum stroke	8 mm
Maximum actuating force	220 N
Protection rating	IP 21 in accordance with EN 60529
Protection class	III

3 General information about KNX Secure

ETS5 Version 5.5 and higher support secure communication in KNX systems. A distinction is made between secure communication via the IP medium using KNX IP Secure and secure communication via the TP and RF media using KNX Data Secure. The following information refers to KNX Data Secure.

In the ETS catalogue, KNX products supporting "KNX-Secure" are clearly identified. 

As soon as a "KNX-Secure" device is included in the project, the ETS requests a project password. If no password is entered, the device is included with Secure Mode deactivated. However, the password can also be entered or changed later in the project overview.

3.1 Start-up with "KNX Data Secure"

For secure communication, the FDSK (Factory Device Setup Key) is required. If a KNX product supporting "KNX Data Secure" is included in a line, the ETS requires the input of the FDSK. This device-specific key is printed on the device label and can either be entered by keyboard or read by using a code scanner or notebook camera.

Example of FDSK on device label:



After entering the FDSK, the ETS generates a device-specific tool key. The ETS sends the tool key to the device to be configured via the bus. The transmission is encrypted and authenticated with the original and previously entered FDSK key. Neither the tool key nor the FDSK key are sent in plain text via the bus.

After the previous action, the device only accepts the tool key for further communication with the ETS.

The FDSK key is no longer used for further communication, unless the device is reset to the factory setting: In this case, all set safety-related data will be deleted.

The ETS generates as many runtime keys as needed for the group communication you want to protect. The ETS sends the runtime keys to the device to be configured via the bus.

Transmission takes place by encrypting and authenticating them via the tool key. The runtime keys are never sent in plain text via the bus.

The FDSK is saved in the project and can be viewed in the project overview.

All keys for this project can also be exported (backup).

During project planning, it can be defined subsequently which functions / objects are to communicate securely. All objects with encrypted communication are identified by the "Secure" icon in the ETS.



3.2 Start-up without "KNX Data Secure"

Alternatively, the device can also be put into operation without KNX Data Secure. In this case, the device is unsecured and behaves like any other KNX device without KNX Data Secure function.

To start up the device without KNX Data Secure, select the device in the 'Topology' or 'Devices' section and set the 'Secure start up' option in the 'Properties' area of the 'Settings' tab to 'Disabled'.

4 The KNX Electromotor Valve Control application programme

4.1 Selection in the product database

Manufacturer	function Technology AS
Product family	Valve actuators
Product type	Valve actuator
Programme name	KNX Electromotor Valve Control

Number of communication objects	59
Number of group addresses	254
Number of associations	255

4.2 Overview of communication objects

4.2.1 General objects

No.	Object name	Function	Length	R	W	C	T	DPT
1	Device LEDs	Brightness	1 byte	-	W	C	-	5.001
		Reduced	1 bit	-	W	C	-	1.001
2	Time	Receive	3 bytes	-	W	C	-	10.001
3	Date	Receive	3 bytes	-	W	C	-	11.001
4	Date/time (DPT 19.001)	Receive	8 bytes	-	W	C	-	19.001
5	Time query	Send	1 bit	-	-	C	T	1.002

4.2.2 Objects for the actuator

No.	Object name	Function	Length	R	W	C	T	DPT
10	Approach position	Receive	1 byte	-	W	C	-	5.001
11	Current valve position	Send	1 byte	R	-	C	T	5.001
12	Actuating value loss	Send	1 bit	R	-	C	T	1.001
13	Forced operation	Force = 1	1 bit	-	W	C	-	1.003
		Force = 0	1 bit	-	W	C	-	1.001
14	Highest actuating value	Send	1 byte	R	-	C	T	5.001
15	Highest actuating value	Receive	1 byte	-	W	C	-	5.001
16	Calibration error (calibration traverse)	Send	1 bit	R	-	C	T	1.005
17	Close valve (heating or cooling interruption)	Receive	1 bit	-	W	C	-	1.003
18	Start calibration traverse manually	Receive	1 bit	-	W	C	-	1.015

4.2.3 Objects for the room temperature controller (RTC)

No.	Object name	Function	Length	R	W	C	T	DPT
30	Setpoint	Receive set temperature	2 bytes	-	W	C	-	9.001
	Base setpoint	Receive comfort temperature	2 bytes	-	W	C	-	9.001
31	Current setpoint	Send	2 bytes	R	-	C	T	9.001
32	Manual setpoint offset	Receive	2 bytes	R	W	C	-	9.002
33	Outdoor temperature compensation	Shift setpoint (K)	2 bytes	-	W	C	-	9.002
		Send (°C)		R	-	C	T	9.001
		Send (K)		R	-	C	T	9.002
35	Control actual value	Send	2 bytes	R	-	C	T	9.001
36	External actual value	Receive	2 bytes	-	W	C	-	9.001
37	Operating mode preset	Receive	1 byte	R	W	C	-	20.102
38	Presence	Receive	1 bit	R	W	C	-	1.018
39	Window status	Send	1 bit	R	-	C	T	1.019
40	Current operating mode	Send	1 byte	R	-	C	T	20.102
41	Heating and cooling actuating value	Send	1 byte	R	-	C	T	5.001
	Heating actuating value	Send	1 byte	R	-	C	T	5.001
42	Actuating value additional stage heating	Send	1 byte	-	-	C	T	5.001
	PWM heating additional stage	Send	1 bit	-	-	C	T	1.001
43	Cooling actuating value	Send	1 byte	R	-	C	T	5.001
44	Actuating value additional stage cooling	Send	1 byte	R	-	C	T	5.001
	PWM cooling additional stage	Send	1 bit	R	-	C	T	1.001
45	Heating mode/cooling mode	Heating = 1, cooling = 0	1 bit	R	-	C	T	1.100
				R	-	C	T	
				-	W	C	-	
				-	W	C	-	
47	Actual value failure	Send	1 bit	R	-	C	T	1.005
51	Outdoor temperature	Receive	2 bytes	-	W	C	-	9.001
53	Window contact 1 (1=window open)	Receive	1 bit	-	W	C	-	1.019
54	Window contact 2 (1=window open)	Receive	1 bit	-	W	C	-	1.019
55	Window contact 3 (1=window open)	Receive	1 bit	-	W	C	-	1.019
56	Window contact 4 (1=window open)	Receive	1 bit	-	W	C	-	1.019
57	Window contact 5 (1=window open)	Receive	1 bit	-	W	C	-	1.019
58	Window contact 6 (1=window open)	Receive	1 bit	-	W	C	-	1.019
59	Window contact 7 (1=window open)	Receive	1 bit	-	W	C	-	1.019
60	Window contact 8 (1=window open)	Receive	1 bit	-	W	C	-	1.019
61	Window contact 9 (1=window open)	Receive	1 bit	-	W	C	-	1.019



No.	Object name	Function	Length	R	W	C	T	DPT
62	Window contact 10 (1=window open)	Receive	1 bit	-	W	C	-	1.019
63	Pump ON/OFF	Send	1 bit	R	-	C	T	1.001

4.2.4 External inputs: Switch function

No.	Object name	Function	Length	R	W	C	T	DPT
81	Channel I1.1	Switching	1 bit	R	W	C	T	1.001
		Priority	2 bit	R	-	C	T	2.001
		Send percentage value	1 byte	R	-	C	T	5.001
		Send value	1 byte	R	-	C	T	5.010
82	Channel I1.2	Switching	1 bit	R	W	C	T	1.001
		Priority	2 bit	R	-	C	T	2.001
		Send percentage value	1 byte	R	-	C	T	5.001
		Send value	1 byte	R	-	C	T	5.010
85	Channel I1	Block = 1	1 bit	-	W	C	-	1.001
		Block = 0	1 bit	-	W	C	-	1.003
91-95	Channel I2 (details: see channel I1)							

4.2.5 External inputs: Push button function

No.	Object name	Function	Length	R	W	C	T	DPT
81	Channel I1.1	Switching	1 bit	-	W	C	T	1.001
		Priority	2 bit	-	-	C	T	2.001
		Send percentage value	1 byte	-	-	C	T	5.001
		Send value	1 byte	-	-	C	T	5.010
82	Channel I1.2	Switching	1 bit	-	W	C	T	1.001
		Priority	2 bit	-	-	C	T	2.001
		Send percentage value	1 byte	-	-	C	T	5.001
		Send value	1 byte	-	-	C	T	5.010
85	Channel I1	Block = 1	1 bit	-	W	C	-	1.001
		Block = 0	1 bit	-	W	C	-	1.003
91-95	Channel I2 (details: see channel I1)							

4.2.6 External inputs: Dimming function

No.	Object name	Function	Length	R	W	C	T	DPT
81	Channel I1	Switching	1 bit	-	W	C	T	1.001
82	Channel I1	Brighter/darker	4 bit	-	-	C	T	3.007
		Brighter	4 bit	-	-	C	T	3.007
		Darker	4 bit	-	-	C	T	3.007
		<i>Double-click</i>						
83	Channel I1.1	Switching	1 bit	-	W	C	T	1.001
		Priority	2 bit	-	-	C	T	2.001
		Send percentage value	1 byte	-	-	C	T	5.001
		Send value	1 byte	-	-	C	T	5.010
85	Channel I1	Block = 1	1 bit	-	W	C	-	1.001
		Block = 0	1 bit	-	W	C	-	1.003
91-95	Channel I2 (details: see channel I1)							

4.2.7 External inputs: Blinds function

No.	Object name	Function	Length	R	W	C	T	DPT
81	Channel I1	Step/stop	1 bit	-	-	C	T	1.010
82	Channel I1	UP/DOWN	1 bit	-	W	C	T	1.008
		UP	1 bit	-	-	C	T	1.008
		DOWN	1 bit	-	-	C	T	1.008
		<i>Double-click</i>						
83	Channel I1.1	Switching	1 bit	-	W	C	T	1.001
		Priority	2 bit	-	-	C	T	2.001
		Send percentage value	1 byte	-	-	C	T	5.001
		Height % ¹	1 byte	-	-	C	T	5.001
		Send value	1 byte	-	-	C	T	5.010
84	Channel I1.2	Slat % ²	1 byte	-	-	C	T	5.001
85	Channel I1	Block = 1	1 bit	-	W	C	-	1.001
		Block = 0	1 bit	-	W	C	-	1.003
91-95	Channel I2 (details: see channel I1)							

¹ Upon double-click with object type = height % + slat %

² Upon double-click with object type = height % + slat %

4.2.8 External inputs: Temperature input function (I2 only)

No.	Object name	Function	Length	R	W	C	T	DPT
91	Channel I2	Actual value for temperature	2 byte	-	-	C	T	9.001

4.2.9 External inputs: Window contact function

No.	Object name	Function	Length	R	W	C	T	DPT
81	Channel I1	Window contact 1	1 bit	R	-	C	T	1.001
85	Channel I1	Block = 1	1 bit	-	W	C	-	1.001
		Block = 0	1 bit	-	W	C	-	1.003
91	Channel I2	Window contact	1 bit	R	-	C	T	1.001
95	Channel I2	Block = 1	1 bit	-	W	C	-	1.001
		Block = 0	1 bit	-	W	C	-	1.003

4.2.10 Objects for diagnostics and maintenance

 These objects provide diagnostic data for our support staff in the event of a problem.
Activation: parameter page **actuator / settings**, activate diagnostic messages.

No.	Object name	Function	Length	R	W	C	T	DPT
111	Diagnosis - motor AD value	Send	2 bytes	-	-	C	T	7.001
112	Diagnosis - position	Send	2 bytes	-	-	C	T	7.001
113	Diagnosis - info text	Send	14 bytes	-	-	C	T	16.001
114	Diagnosis - time and date	Send	8 bytes	-	-	C	T	19.001
115	Diagnosis - position: valve open	Send	2 bytes	-	-	C	T	7.001
116	Diagnosis - position: valve closed	Send	2 bytes	-	-	C	T	7.001
117	Diagnosis - position: valve completely closed	Send	2 bytes	-	-	C	T	7.001

4.3 Description of communication objects

4.3.1 General objects

Object 1: Device LEDs

Only available with the setting *Reduce brightness of LEDs = via bus*.

Object type	Function
<i>Via switch object</i>	1 = reduce brightness 0 = normal brightness
<i>Via percentage value</i>	0..100% = LED brightness

Object 2: Receive time

Receives the current time.
DPT10.001

Object 3: Receive date

Receives the current date.
DPT11.001

Object 4: Receive date/time

Receives the current date and time together.
DPT19.001

Object 5: Send time query

Sends time query to bus clock to receive the current time.

4.3.2 Objects for the actuator function

Object 10: Approach position

Receives the actuating value specified by the room temperature controller (0...100%).
The valve is positioned accordingly.

 This object is only available if the internal room temperature controller (RTC) is not activated.³

Object 11: Current valve position

Sends the actual valve position (0...100%) to the bus.

Object 12: Send actuating value loss

Only available if on the Actuator parameter page - Settings of the parameters
Monitor the actuating value = yes.

If monitoring is selected, the room thermostat must receive an actuating value telegram regularly.

Recommendation: To ensure trouble-free operation, the cyclical transmission time to the room thermostat should be no longer than half the monitoring time.

Example: Monitoring time 30 min, cyclical transmission time to thermostat less than or equal to 15 min.

If no new actuating value is received within the configured monitoring time, failure of the room thermostat is assumed and an emergency program is started.

See **emergency program** parameter page.

 This object is only available if the internal room temperature controller (RTC) is not activated.⁴

Object 13: Forced operation

The direction of action of the force telegram is adjustable.

Standard:

1 = activate force

0 = end force.

 After download or reset, forced operation is always deactivated.

Object 14: Send highest actuating value

Sends its own actuating value to the other actuators to start a comparison.

³ See **General** parameter page

⁴ See **General** parameter page

Object 15: Receive highest actuating value

Receives the actuating values of the other actuators (other rooms) in order to compare them with the own actuating value and send the own actuating value to the heating boiler if it is higher than the other values.

Object 16: Send calibration error (calibration traverse)

Error message: The motor is too heavily loaded.

Possible causes: Installation error, incorrect or defective valve or device defect.

1 = error

0 = no error

Object 17: Receive close valve (heating or cooling interruption)

A 1 on this object starts the heating⁵ or cooling interruption, i.e. the actuating value is no longer taken into account and the valve is permanently closed.

If the valve protection is activated, it is also executed during the heating or cooling interruption.

The valve remains in the 0% position until the heating⁶ or cooling interruption is cancelled by a 0.

Afterwards, the actuating value sent before or during the heating or cooling interruption is approached. This position is only changed when an actuating value other than the actuating value valid before the heating or cooling interruption is received.

Object 18: Receive start calibration traverse manually

Maintenance object:

A new calibration process can be started with a 1 on this object.

The valve is opened and closed several times in succession.

This causes the end positions of the valve (fully open/fully closed) to be captured and stored anew.

⁵ Summer mode

⁶ Summer mode

4.3.3 Objects for the room temperature controller (RTC)

Object 30: Base setpoint - Receive comfort temperature, receive setpoint - set temperature

The base setpoint⁷ or setpoint⁸ is first specified via the application at start-up and stored in the *base setpoint or setpoint* object.

Afterwards, it can be specified again at any time via this object (limited by the minimum or maximum valid setpoint).

The object can be written to without restriction.

Object 31: Current setpoint – send

Sends the current temperature setpoint as DPT 9.001.

Object 32: Manual setpoint offset

Offsetting set temperature:

The object receives a temperature difference as DPT 9.002. The desired room temperature (current setpoint) can be adjusted against the base setpoint by this difference.

The following applies in comfort mode (heating):

Current setpoint = base setpoint + manual setpoint offset

Values outside the configured range (*min/max basic setpoint or max valid setpoint offset*) are limited to the highest or lowest value.

Comment:

The offset always refers to the set base setpoint and not to the current setpoint.

Exception: If no operating modes are used⁹

⁷ Parameter *Use operating modes* = yes

⁸ Parameter *Use operating modes* = no

⁹ Parameter *Use operating modes* = no on parameter page *RTC - settings*

Object 33: Outdoor temperature compensation – send (K or °C) / shift setpoint

The function of the object is defined by the parameter *setpoint correction at high outdoor temperature*.

Setpoint correction at high outdoor temperature	Object function	Data direction
Receive only	Receives setpoint correction for outdoor temperature compensation.	Receive
Calculate internally and send	Reports the current setpoint correction as an amount or as a differential. The format of the correction value (see following table) is set on the <i>Setpoint adjustment</i> parameter page.	Send

Format of correction value	Object function	Example
Absolute	Sends the amount: Unadjusted base setpoint + setpoint correction as setpoint for additional temperature controllers.	Unadjusted base setpoint = 20 °C. Setpoint correction = +2 K The object transmits: 22 °C
Relative	Calculated setpoint correction (in Kelvin) based on outdoor temperature.	Unadjusted base setpoint = 20 °C. Setpoint correction = +2 K The object sends: 2 K

Object 35: Control actual value

Sends the actual value actually used by the room temperature controller.

Object 36: External actual value

Only available if *external actual value* has been selected as a source.

Receives the room temperature from another measurement point via the bus.
This object can be activated on the *Actual value* parameter page.

Object 37: Operating mode preset

Can be used to directly activate one of 4 operating modes.

- 1 = Comfort
- 2 = Standby
- 3 = Night,
- 4 = Frost protection (heat protection)

The configured *operating mode after reset* is active until a new valid operating mode is received or changed at the device by the user.

Object 38: Presence

The status of a presence detector (e.g. push button, motion detector) can be received via this object.

1 on this object activates comfort operating mode.

Object 39: Send window status

The device can obtain the window status from different sources.

The object sends the currently valid status from all window contacts (OR-linked).

As soon as at least 1 window is open, the Window = open status applies.

- 1 = window open
- 0 = window open

The status is always sent without delay.

See below: Objects *window contact 1-10* and parameter page **window contact**.

Object 40: Current operating mode.

Sends the current HVAC operating mode.

The transmission behaviour can be defined on the **operating mode** parameter page.

Value	HVAC operating mode
1	Comfort
2	Standby
3	Night
4	Frost protection/heat protection

Object 41: Heating actuating value or heating and cooling actuating value.

Sends the current heating (0...100%) or heating and cooling actuating value if the *output of cooling actuating value* parameter has been set to *together with heating actuating value* (**Settings** parameter page).

Object 42: Additional heating stage actuating value or PWM additional heating stage

Sends the actuating value for the additional heating stage depending on the configuration, as 1 bit PWM, or 1 byte percentage telegram.

This object is only available if the additional stage is used.

Object 43: Cooling actuating value

Sends the current actuating value or cooling switching command depending on the type of control selected on the **Cooling control** parameter page.

The object is only available if the cooling function and the output on separate object or automatic changeover has been selected on the **Settings** parameter page (*Control functions used = heating and cooling*).

Object 44: Additional cooling stage actuating value or PWM additional cooling stage

Sends the actuating value for the additional cooling stage depending on the configuration, as 1 bit PWM, or 1 byte percentage telegram.

This object is only available if the additional stage is used.

Object 45: Send heating/cooling operation, or changeover between heating and cooling

The object is available if the cooling function has been selected on the **Settings** parameter page (*control = heating and cooling*).

The function of the object depends on the *changeover between heating and cooling* parameter on the **Cooling control** parameter page.

Parameter: Changeover between heating and cooling	Function
<i>automatic</i>	Reports whether the room thermostat is currently operating in heating or cooling mode.
<i>via object</i>	Receives the switch command for changeover between heating and cooling mode.

The telegram format can be set on the **Settings** parameter page:

Parameter: Format of Heating/cooling object	Telegram format
<i>DPT1.100</i>	Heating = 1, cooling = 0
<i>Inverted</i>	Heating = 0, cooling = 1

Object 47: Send actual value failure

Only available if the actual value monitoring is activated (*Monitor actual value = yes*).

Sends a 1, as soon as one of the selected sources for the actual value provides an unusable value, or (if selected) if no new actual value telegram has been received by the *External actual value* object within the actual value monitoring time.

Unusable temperature values might occur if a temperature sensor is mechanically damaged, or if the electrical connection is interrupted or short-circuited.



If the average value is determined from several sources and actual values fail, control continues as long as at least one valid actual value is available.

Object 51: Receive outdoor temperature

Only available if the *setpoint correction at high outdoor temperature* parameter has been set to *calculate internally and send*.

Receives the outdoor temperature for internal calculation of the setpoint adjustment in cooling mode

Objects 53-62: Window contact 1-10 (1=window open)

Up to 10 objects are available for window contacts.

See parameter page **Window contact**.

The status of several window contacts can be received via these objects.

All objects are connected via an OR link: As soon as one of these objects receives a 1, the window status = window open applies and the frost/heat protection mode is activated.

Feedback via object *Send window status*.

Object 63 "Pump ON/OFF"

Control of the supply pump depending on the actuating value:

0% = OFF, > 0% = ON.

Available if pump control is activated (parameter page *General*)

4.3.4 Objects for the external inputs: Switch function

Object 81: Channel I1.1

First output object of the channel (first telegram).

4 telegram formats can be set:

Switching ON/OFF, priority, send percentage value, send value.

Object 82: Channel I1.2

Second output object of the channel (second telegram).

4 telegram formats can be set:

Switching ON/OFF, priority, send percentage value, send value.

Object 85: Channel I1 block = 1, or block = 0

The channel is blocked via this object.

The acting direction of the block object and behaviour when the block is set or cancelled can be configured.

Objects 91, 92, 95

Objects for channel I2

4.3.5 Objects for the external inputs: Push button function

Object 81: Channel I1.1

First output object of the channel (first telegram).

4 telegram formats can be set:

Switching ON/OFF, priority, send percentage value, send value.

Object 82: Channel I1.2

Second output object of the channel (second telegram).

4 telegram formats can be set:

Switching ON/OFF, priority, send percentage value, send value.

Object 85: Channel I1 block = 1, or block = 0

The channel is blocked via this object.

The acting direction of the block object and behaviour when the block is set or cancelled can be configured.

Objects 91, 92, 95

Objects for channel I2

4.3.6 Objects for the external inputs: Dimming function

Object 81: Channel I1.1 switching

Switches the dimmer on and off.

Object 82: Channel I1.1 brighter, darker, brighter/darker

4-bit dimming commands.

Object 83: Channel I1.1 switching, priority, percentage..

Output object for the additional function with double-click.

4 telegram formats can be set:

Switching ON/OFF, priority, send percentage value, send value.

Object 85: Channel I1 block = 1, or block = 0

The channel is blocked via this object.

The acting direction of the block object and behaviour when the block is set or cancelled can be configured.

Objects 91, 92, 93, 95

Objects for channel I2

4.3.7 Objects for the external inputs: Blinds function

Object 81: Channel I1 step/stop

Sends step/stop commands to the blind actuator.

Object 82: Channel I1 UP/DOWN, UP, DOWN

Sends operating commands to the blind actuator.

Object 83: Channel I1.1 switching, priority, percentage., height %

Output object for the additional function with double-click.

5 telegram formats can be set:

Switching ON/OFF, priority, send percentage value, send value, height %.

Object 84: Channel I1.1 slat %

Slat telegram for positioning the blinds upon double-click (together with object height %, with *object type = height + slat*).

Object 85: Channel I1 block = 1, or block = 0

The channel is blocked via this object.

The acting direction of the block object and behaviour when the block is set or cancelled can be configured.

Objects 91–95

Objects for channel I2

4.3.8 Object for the external inputs: Temperature input function

Object 91: Channel I2 actual value for temperature

Sends the temperature measured at input I2 (remote sensor or floor temperature sensor).



The temperature input function is only possible with input I2.

4.3.9 Objects for the external inputs: Window contact function

Object 81: Channel I1 window contact 1

First output object of the channel.
Switch telegram.

Object 85: Channel I1 block = 1, or block = 0

The channel is blocked via this object.
The acting direction of the block object and behaviour when the block is set or cancelled can be configured.

Objects 91 and 95

Objects for channel I2.

4.3.10 Objects for diagnostics and maintenance

 These objects provide diagnostic data for our support staff in the event of a problem.
Activation: parameter page **actuator / settings**, *activate diagnostic messages*.

Object 111: Diagnosis – Motor AD value

Raw data on motor load.

Object 112: Diagnosis – Send position

Sends the current position.

Object 113: Diagnosis – Send info text

Sends a diagnostic text.¹⁰

Object 114: Diagnosis – Send time and date

Sends time and date of the internal clock.

Object 115: Diagnosis – Position: Send valve open

Sends the position at which the valve was detected as open.

Object 116: Diagnosis – Position: Send valve closed

Sends the position at which the valve was detected as closed.

Object 117: Diagnosis – Position: Send valve completely closed

Sends the detected maximum possible closing position.

¹⁰ for evaluation by a support staff member

4.4 Parameter pages overview

The device consists of one general block and 5 main functional blocks.

Parameter page	Description
<i>General</i>	LED settings, activation of room temperature controller (RTC).
<i>RTC</i>	
<i>Settings</i>	General settings for temperature control
<i>Actuating value</i>	Minimum and maximum actuating value etc.
<i>Actual value</i>	Source for actual value measurement, actual value monitoring etc.
<i>Operating mode</i>	Operating mode after reset, presence sensor etc.
<i>Setpoints</i>	Base setpoint, frost protection, dead zone, heat protection etc.
<i>Heating control</i>	Control parameters, installation type etc. for heating mode.
<i>Additional stage heating</i>	Type of actuating value, proportional band, transmission behaviour.
<i>Cooling control</i>	Control parameters, installation type etc. for cooling mode.
<i>Additional stage cooling</i>	Type of actuating value, proportional band, transmission behaviour.
<i>Setpoint adjustment</i>	Settings for setpoint adjustment at high outdoor temperatures
<i>Emergency program</i>	Response to failure of actuating value or actual value. Settings of the monitoring function.
<i>Window contact</i>	Source for window status, number of contacts, delay etc.
<i>Pump control</i>	
<i>Pump control</i>	Pump settings
<i>Actuator</i>	
<i>Settings</i>	General settings for the actuator: heating/cooling, valve protection, force function etc.
<i>Valve characteristics</i>	Specific valve settings: Valve characteristic, direction of action, calibration strategy etc.
<i>Force</i>	Response in forced operation.
<i>Diagnostic messages</i>	Parameters for maintenance and diagnostics.
<i>External inputs I1, I2</i>	
<i>Configuration options</i>	Function of the input, debounce time, number of telegrams, block function, etc. Additionally in the case of I2: Selection of the temperature sensor, temperature calibration, etc.
<i>Switch object 1, 2</i>	Object type, transmission behaviour, etc. can be set for each object individually.
<i>Push button object 1, 2</i>	Object type, transmission behaviour, etc. can be set for each object individually.
<i>Dimming</i>	Type of control.
<i>Blinds</i>	Type of control.
<i>Double-click</i>	Additional telegrams for <i>Dimming</i> and <i>Blinds</i> .
<i>Window contact</i>	Direction of action, cycl. Transmission, etc.

 If the external input I1 is used as the source for the window contact (see parameter page *RTC/window contact*), the channel *Input I1* is hidden.

 If the external input I2 is used as the source for the actual value (see parameter page *RTC/actual value*), the channel *Input I2* is hidden.

4.5 General parameters

Designation	Values	Description
<i>Function of the LEDs</i>	<i>Always off</i> <i>Position display</i>	The LEDs always remain off The 5 LEDs indicate the current valve position as follows (from bottom to top): All OFF: Position 0% 1. LED: Position > 0...20% 2. LED: Position > 20...40% 3. LED: Position > 40...60% 4. LED: Position > 60...80% 5. LED: Position > 80...100%
<i>Reduce brightness of the LEDs</i>	<i>never</i> <i>always</i> <i>via bus</i>	The LEDs should: Shine at maximum brightness at all times. Always shine at the specified brightness Be able to be reduced or dimmed via bus telegrams.
<i>Object type</i>	<i>via switch object</i> <i>via percentage value</i>	Brightness reducible via switch telegram. The brightness of the LEDs can be set as desired via dimming telegrams.
<i>Value for reduced brightness</i>	<i>0-100%</i> Default = 30%	LED brightness for the setting <i>always</i> or <i>via bus</i> (switch object).
<i>Time/date format</i>	<i>no time/date</i> <i>DPT 10.001 / DPT 11.001</i> DPT 19.001	Time and date are not received and not used. ¹¹ Time and date via 2 separate objects. 1 Common object for time and date.
<i>Send time request after reset every minute (until reception of time/date)</i>	<i>No</i> <i>yes</i>	Synchronisation behaviour of the internal clock after download or reset.
<i>Send time request cyclically</i>	do not send <i>every hour</i> <i>every 2 hours</i> <i>every 3 hours</i> <i>every 6 hours</i> <i>every 12 hours</i> <i>every 24 hours</i>	Synchronisation interval of the internal clock.
<i>Activate room temperature controller (RTC)</i>	No <i>yes</i>	The actuating value for the actuator is received via the bus. The internal room temperature controller is used and controls the actuator. See chapter: Parameters for the heating actuator.

¹¹ The time data are useful for diagnostic purposes and enable time-dependent execution of the valve protection function (see parameter page **Actuator – Settings**).

Designation	Values	Description
<i>Activate pump control</i>	<i>no</i> <i>yes</i>	Is a pump to be controlled?

4.6 Parameters for the heating controller

4.6.1 Settings

Designation	Values	Description
<i>Control functions used</i> ¹²	only heating <i>Heating and cooling</i> <i>Only cooling</i>	Heating mode only. Heating and cooling mode Only cooling mode
<i>Changeover between heating and cooling</i>	automatic <i>via object</i>	The controller automatically switches to cooling mode if the actual temperature is above the setpoint. The cooling mode can only be activated on the bus via object (heating =../cooling =..). Cooling mode remains off, as long as this object is not set.
<i>Format of heating/cooling object</i>	DPT1.100 (heating=1/cooling=0) <i>Inverted</i> <i>(heating=0/cooling=1)</i>	Standard format. Compatible with RAM 713 S, VARIA etc.
<i>Output of the cooling actuating value</i> ¹³	<i>on separate object</i> <i>Together with heating actuating value</i>	For 4-pipe systems: The actuating values for heating and cooling are sent separately by means of 2 objects. For 2-pipe systems: The actuating value is always sent to the <i>actuating value heating/cooling</i> object, independent of whether heating or cooling mode is active.
<i>Setpoint correction at high outdoor temperature</i>	None <i>Receive only</i>	Function is deactivated The correction value is received by the bus and the own setpoint is adjusted to the increase in outside temperature.

¹² Only for user-defined control.

¹³ Only when changeover between heating and cooling via object.

Designation	Values	Description
	<i>Calculate internally and send</i>	The device calculates the correction value, sends it to other controllers and adjusts the own setpoint to the increase in outside temperature. See in the Appendix: <u>Setpoint correction</u>
<i>Use operating modes</i>	<i>no</i> <i>yes</i>	The setpoint can be specified as an absolute value via an object. ¹⁴ The setpoint is calculated based on the operating mode, the base setpoint, the manual shift, and the presence object.
<i>Sending of actuating value¹⁵</i>	<i>at change of 1%</i> <i>at change of 2%</i> <i>at change of 3%</i> <i>at change of 5%</i> <i>at change of 7%</i> <i>at change of 10%</i> <i>at change of 15%</i>	After what percentage change ¹⁶ in the actuating value is the new value to be transmitted. Small values increase control accuracy, but also the bus load.
<i>Cycl. Sending of actuating value¹⁷</i>	<i>not cyclically, only in the event of change</i> <i>every 2 min, every 3 min</i> <i>every 5 min, every 10 min</i> <i>every 15 min, every 20 min</i> <i>every 30 min, every 45 min</i> <i>every 60 min,</i>	How often is the current heating actuating value to be sent (regardless of changes)?

¹⁴ Frost and heat protection are always ensured, regardless of this.

¹⁵ Applies to both the heating actuating value and the cooling actuating value (if available).

¹⁶ Change since last transmission

¹⁷ Applies to both the heating actuating value and the cooling actuating value (if available).

4.6.2 Actual value

On this parameter page, the source is selected which is used as the actual value for control. This can be the temperature sensor integrated in the device, an external sensor, an actual value via object, or a combination of these.

 If the external input I2 is used as the source for the actual value (see parameter page *RTC/actual value*), the channel *Input I2* is hidden.

Designation	Values	Description
<i>Source for actual value</i>	<p><i>Internal sensor</i></p> <p><i>External actual value object</i></p> <p><i>Sensor at I2</i></p> <p><i>Average value from internal + I2</i></p> <p><i>Average value of int. + ext. actual value object</i></p> <p><i>Average value from internal + I2 + ext. actual value object</i></p> <p><i>Average value from I2 + ext. actual value object</i></p>	<p>Control actual value. The device measures and controls the room temperature via the internal sensor. (Control actual value = internally measured temperature).</p> <p>The room temperature is solely acquired via the bus.</p> <p>External sensor at I2.</p> <p>Average value of the internal value and the value measured at I2.</p> <p>The device calculates the average value of the room temperature received from the bus and the internal measurement.</p> <p>Use average value from 3 sources: I2 + internal + bus.</p> <p>Use average value of I2 and bus.</p>
<i>Temperature calibration internal sensor¹⁸</i>	- 5 K .. +5 K (resolution 0.1 K)	Correction value for temperature measurement if sent temperature deviates from the actual ambient temperature. Example: temperature = 21 °C sent temperature = 20.5 °C Correction value = 0.5 K
<i>Temperature calibration sensor at I2¹⁹</i>	- 5 K .. +5 K (resolution 0.1 K)	Correction value for the external temperature sensor at I2.

¹⁸ If used

¹⁹ If used

Designation	Values	Description
<i>Send actual value in the event of change of</i>	<i>not due to a change</i> <i>0.2 K</i> <i>0.3 K</i> <i>0.5 K</i> <i>0.7 K</i> <i>1 K</i> <i>1.5 K</i> <i>2 K</i>	Only send cyclically (if enabled) Send if the value has changed by the selected amount since the last transmission.
<i>Send actual value cyclically</i>	<i>do not send cyclically</i> <i>every min,</i> <i>every 2 min, every</i> <i>3 min</i> <i>every 5 min, every</i> <i>10 min,</i> <i>every 15 min, every</i> <i>20 min,</i> <i>every 30 min, every</i> <i>45 min,</i> <i>every 60 min</i>	How often should the current measured value be resent?
<i>Monitor actual value</i>	<i>no</i>	No monitoring.
	<i>yes</i>	All selected actual value sources are monitored. In case of an error, the object sends <i>actual value failure</i> error telegrams.  As long as at least one valid actual value remains available, this will be continued to be used for control. This is the case if the average value is determined out of 2 or 3 sources. If no valid actual value is available, control continues according to the parameters under emergency program.

4.6.3 Operating mode

Only available if the operating modes are activated on the *RTC settings* parameter page.

Designation	Values	Description
<i>Operating mode after reset</i>	<i>Frost protection</i> <i>Temperature reduction at night</i> Standby <i>Comfort</i>	Operating mode after start-up or reprogramming
<i>Type of presence sensor</i>	Presence detector <i>Presence button</i>	The presence sensor activates the comfort operating mode Comfort operating mode as long as the presence object is set. If, after the presence object has been set, the operating mode default object is sent again, the new operating mode is accepted and the state of the presence object will be ignored. If the presence object is set during night/frost mode, it is reset after the configured comfort extension has expired ²⁰ (see below). The presence object is not reported back on the bus
<i>Comfort extension by presence button in night and frost protection mode</i>	<i>none</i> <i>30 min</i> <i>1 hour</i> <i>1.5 hours</i> 2 hours <i>2.5 hours</i> <i>3 hours</i> <i>3.5 hours</i>	Telegrams from the presence button are not considered. Party switching: This allows the controller to change via the presence object from night/frost mode to comfort mode again for a set length of time. The time limit is omitted if the device was previously in standby mode. Comfort mode is only cleared with the next manual or bus controlled change of the operating mode.
<i>Cycl. transmission of current operating mode</i>	<i>not cyclically, only in the event of change</i>	How often should the current operating mode be sent?

²⁰ Exception: If a window is opened (window object = 1), the room thermostat switches to frost protection mode



Designation	Values	Description
	<i>every 2 min, every 3 min every 5 min, every 10 min every 15 min, every 20 min every 30 min, every 45 min every 60 min</i>	

4.6.4 Setpoints

 This parameter page contains the setpoints for both heating and cooling mode.²¹

Designation	Values	Description
<i>(Base) setpoint after loading the application</i>	18 °C, 19 °C, 20 °C 21 °C , 22 °C, 23 °C, 24 °C, 25 °C, 26 °C, 27 °C, 28 °C, 29 °C, 30 °C, 31 °C, 32 °C	Output setpoint for temperature control.
<i>Minimum valid base setpoint</i>	5 °C, 6 °C, 7 °C, 8 °C, 9 °C, 10 °C , 11 °C, 12 °C, 13 °C, 14 °C, 15 °C, 16 °C 17 °C, 18 °C, 19 °C, 20 °C	If a received base setpoint (<i>base setpoint</i> object) is lower than the value set here, it will be limited to this value.
<i>Maximum valid base setpoint</i>	20 °C, 21 °C, 22 °C 23 °C, 24 °C, 25 °C 27 °C, 30 °C, 32 °C	If a received base setpoint (<i>base setpoint</i> object) is higher than the value set here, it will be limited to this value.
<i>Maximum valid setpoint offset²²</i>	+/- 1 K, +/- 2 K, +/- 3 K, +/- 4 K, +/- 5 K , +/- 6 K, +/- 7 K, +/- 8 K, +/- 9 K, +/- 10 K	Limits the possible setting range for the setpoint offset function. Applies to values received via <i>Manual setpoint value offset</i> object.
<i>Setpoint offset applies²³</i>	<i>Only in comfort mode</i> <i>With comfort and standby mode</i> <i>With comfort, standby and night mode</i>	The setpoint offset: is only considered in the selected modes, and is ineffective in all other modes.
<i>current setpoint (in comfort mode)</i>	<i>Sends actual value (heating < > cooling)</i>	Feedback of current setpoint via the bus: The setpoint actually being used for control has always to be sent (= current setpoint). Example with base setpoint of 21 °C and dead zone of 2 K: During heating, 21 °C is sent, and during cooling, base setpoint + dead zone is sent (21 °C + 2 K = 23 °C)

²¹ Depending on the control function used.

²² Only available if the operating modes are activated on the RTC settings parameter page.

²³ Only available if the operating modes are activated on the RTC settings parameter page.

Designation	Values	Description
	<i>Send average value between heating and cooling</i>	Same value in comfort mode during both heating and cooling mode, i.e.: Base setpoint + half dead zone is sent, to prevent occupants from being confused. Example with base setpoint of 21 °C and dead zone of 2 K: Mean value = 21°+1 K = 22 °C Although control takes place at 21 °C or 23 °C
Heating		
<i>Reduction in standby mode²⁴ (during heating)</i>	<i>0K, 0.5 K, 1 K, 1.5 K 2 K, 2.5 K, 3 K 3.5 K, 4 K, 4.5 K, 5 K, 6 K, 7 K, 8 K</i>	Example: With a base setpoint value of 21 °C in heating mode and a reduction of 2 K, the device controls with a setpoint of 21 – 2 = 19 °C.
<i>Reduction in night mode²⁵ (during heating)</i>	<i>0 K, 0.5 K, 1 K, 1.5 K 2 K, 2.5 K, 3 K 3.5 K, 4 K, 4.5 K, 5 K, 6 K, 7 K, 8 K</i>	By what value should the temperature be reduced in night mode?
<i>Setpoint for frost protection mode (during heating)</i>	<i>3 °C, 4 °C, 5 °C 6 °C, 7 °C, 8 °C 9 °C, 10 °C</i>	Preset temperature for frost protection mode in heating mode (Heat protection applies in cooling mode).
Cooling		
<i>Dead zone between heating and cooling</i>	<i>0 K ²⁶ 0.5 K ²⁷ 1 K 2 K 3 K 4 K 5 K 6 K</i>	Specifies the buffer zone between setpoints for heating and cooling mode.
<i>Increase in standby mode (during cooling)</i>	<i>0K, 0.5 K, 1 K, 1.5 K 2 K, 2.5 K, 3 K 3.5 K, 4 K, 4.5 K, 5 K, 6 K, 7 K, 8 K</i>	The standby temperature is increased in cooling mode
<i>Increase in night mode (during cooling)</i>	<i>0 K, 0.5 K, 1 K, 1.5 K 2 K, 2.5 K, 3 K 3.5 K, 4 K, 4.5 K, 5 K, 6 K, 7 K, 8 K</i>	See increase in standby mode

²⁴ Only available if the operating modes are activated on the RTC settings parameter page.

²⁵ Only available if the operating modes are activated on the RTC settings parameter page.

²⁶ Only available with changeover between heating and cooling via object

²⁷ Only available with changeover between heating and cooling via object

Designation	Values	Description
<i>Setpoint for heat protection mode (during cooling)</i>	42 °C (i.e. virtually no heat protection) 29 °C, 30 °C, 31 °C 32 °C, 33 °C, 34 °C 35 °C	Heat protection represents the maximum permitted temperature for the controlled room. It performs the same function during cooling as frost protection mode during heating, e.g. saves energy while prohibiting non-permitted temperatures.
<i>Cycl. transmission of current setpoint</i>	not cyclically, only in the event of change <i>every 2 min, every 3 min every 5 min, every 10 min, every 15 min, every 20 min, every 30 min, every 45 min, every 60 min</i>	How often should the currently valid setpoint be sent? Only send in the event of a change. Send cyclically

4.6.5 Control (heating)

Designation	Values	Description
<i>Number of heating stages</i>	Only one heating stage <i>Main stage and additional stage</i>	Choice of 1- or 2-stage heating
<i>Setting the control parameters</i>	Via installation type <i>user-defined</i>	Standard application Professional use: Configure P/PI controller yourself
<i>Installation type</i>	Radiator heating system <i>Underfloor heating</i>	PI controller with: Integration time = 90 minutes Bandwidth = 2.5 K Integration time = 30 h Bandwidth = 4 K
User-defined parameter		
<i>Proportional band of heating controller</i>	1 K, 1.5 K, 2 K, 2.5 K, 3 K 3.5 K, 4 K, 4.5 K 5 K, 5.5 K, 6 K 6.5 K, 7 K, 7.5 K 8 K, 8.5 K	Professional setting for adapting the control response to the room. Small values cause large changes in actuating values, larger values cause finer actuating value adjustment.
<i>Integrated time of the heating controller</i>	<i>pure P controller</i> 15 min, 30 min, 45 min 60 min, 75 min, 90 min 105 min, 120 min, 135 min, 150 min, 165 min, 180 min 195 min, 210 min 4 h, 5 h, 10 h, 15 h, 20 h, 25 h, 30 h, 35 h	The integration time determines the response time of the control. It establishes the increase by which the output actuating value is raised in addition to the P share. The I share remains active for as long as there is a control deviation. The I share is added to the P share.

4.6.6 Additional stage heating

Temperature control is done via a proportional controller.

Designation	Values	Description
<i>Type of actuating value</i>	Percent <i>PWM</i>	Control is done via a proportional controller. Continuous actuating value 0-100% Pulse-width modulated switching actuating value.
<i>Difference between main stage and additional stage</i>	0 K, 0.5 K, 1 K 1.5 K, 2 K , 2.5 K 3 K, 3.5 K, 4 K	Defines the negative distance between the current setpoint and the setpoint of the additional stage. Example with base setpoint of 21 °C and difference of 1 K: The main stage controls with the base setpoint and the addition stage controls with Base setpoint – 1 K = 20 °C
<i>Proportional band</i>	1 K, 1.5 K, 2 K, 2.5 K 3 K, 3.5 K, 4 K , 4.5 K 5 K, 5.5 K, 6 K, 6.5 K 7 K, 7.5 K, 8 K, 8.5 K	With continuous additional stage, Professional setting for adapting the control response to the room. Large values cause finer changes to the control variables with the same control deviation and more precise control than smaller values.
<i>PWM period</i>	3-30 min Default: 5 min	An actuation cycle consists of a switch-on and a switch-off process and forms a PWM period. Example: Actuating value = 20%, PWM time = 10 min: In an actuating cycle of 10 min, 2 min switched on and 8 min switched off (i.e. 20% on/80% off).
<i>Sending of actuating value</i>	At change by 1% At change by 2% At change by 3% At change by 5% At change by 7% At change by 10% At change by 15%	After what percentage change in the actuating value is the new value to be transmitted. Small values increase control accuracy, but also the bus load.

Designation	Values	Description
<i>Send cyclically</i>	<i>do not send cyclically</i> <i>every 2 min, every 3 min every 5 min, every 10 min, every 15 min, every 20 min, every 30 min, every 45 min, every 60 min</i>	How often should it be resent?

4.6.7 Cooling control

Designation	Values	Description
<i>Number of cooling stages</i>	Only one cooling stage <i>Main stage and additional stage</i>	Choice of 1- or 2-stage cooling
<i>Setting the control parameters</i>	Via installation type <i>user-defined</i>	Standard application Professional use: Configure P/PI controller yourself
<i>Installation type</i>	Cooling surface <i>Fan coil unit</i>	PI controller with: Integration time = 240 minutes Bandwidth = 5 K Integration time = 180 minutes Bandwidth = 4 K
User-defined control parameter		
<i>Proportional band of the cooling controller</i>	1 K, 1.5 K, 2 K, 2.5 K, 3 K 3.5 K, 4 K , 4.5 K 5 K, 5.5 K, 6 K 6.5 K, 7 K, 7.5 K 8 K, 8.5 K	Professional setting for adapting the control response to the room. Large values cause finer changes to the actuating value with the same control deviation and more precise control than smaller values.
<i>Integration time of the cooling controller</i>	<i>pure P controller</i> <i>pure P controller</i> 15 min, 30 min, 45 min 60 min, 75 min, 90 min 105 min, 120 min, 135 min, 150 min, 165 min, 180 min 195 min, 210 min 4 h, 5 h, 10 h, 15 h, 20 h, 25 h, 30 h, 35 h	See appendix: Temperature control Only for PI controller: The integration time determines the response time of the control. It establishes the increase by which the output actuating value is raised in addition to the P share. The I share remains active for as long as there is a control deviation. The I share is added to the P share.

4.6.8 Additional stage cooling

Control is done via a proportional controller.

Designation	Values	Description
<i>Type of actuating value</i>	Percent <i>PWM</i>	Continuous actuating value 0-100% Pulse-width modulated switching actuating value.
<i>Difference between main stage and additional stage</i>	<i>0 K, 0.5 K, 1 K</i> <i>1.5 K, 2 K, 2.5 K</i> <i>3 K, 3.5 K, 4 K</i>	Defines the positive distance between the current setpoint and the setpoint of the additional stage. Example with base setpoint of 21 °C and difference of 1 K: The main stage controls with the base setpoint and the addition stage controls with Base setpoint + 1 K = 22 °C
<i>Proportional band</i>	<i>1 K, 1.5 K, 2 K, 2.5 K</i> <i>3 K, 3.5 K, 4 K, 4.5 K</i> <i>5 K, 5.5 K, 6 K, 6.5 K</i> <i>7 K, 7.5 K, 8 K, 8.5 K</i>	With continuous additional stage, Professional setting for adapting the control response to the room. Large values cause finer changes to the control variables with the same control deviation and more precise control than smaller values.
<i>PWM period</i>	<i>3-30 min</i> Default: 5 min	An actuation cycle consists of a switch-on and a switch-off process and forms a PWM period. Example: Actuating value = 20%, PWM time = 10 min: In an actuating cycle of 10 min, 2 min switched on and 8 min switched off (i.e. 20% on/80% off).
<i>Sending of actuating value</i>	<i>At change by 1%</i> <i>At change by 2%</i> <i>At change by 3%</i> At change by 5% <i>At change by 7%</i> <i>At change by 10%</i> <i>At change by 15%</i>	After what percentage change in the actuating value is the new value to be transmitted. Small values increase control accuracy, but also the bus load.

Designation	Values	Description
<i>Start setpoint</i>	15 °C-30 °C Default: 21 °C	(Only with format = absolute). This is the base setpoint for the external controller. If correction is required, it is added to this and the result is sent as a new, adjusted set point
<i>Maximum adjustment</i>	Unlimited ²⁸ Until heat protection temp. reached ²⁹ +3 K +5 K +7 K	The setpoint continues to increase as long as the outside temperature increases. The setpoint is only increased up to the configured heat protection temperature. The setpoint increase ends as soon as the adjustment has achieved the set value.
<i>Send setpoint adjustment</i>	do not send cyclically every 2 min, every 3 min every 5 min, every 10 min, every 15 min, every 20 min, every 30 min, every 45 min, every 60 min	How often should it be resent?

²⁸ In case of setpoint correction at high temperatures = internally calculate and send.

²⁹ In case of setpoint correction at high temperatures = only receive.

4.6.10 Emergency program

In case of actual value failure, the valve can be moved to a fixed position

Designation	Values	Description
<i>Behaviour during emergency program³⁰</i>	<i>Fixed valve position</i> <i>Continue regulation with internal sensor</i>	The valve is moved to a predefined position. The measurement value of the integrated temperature sensor is used as the actual value for the control.
<i>Fixed valve position</i>	0..25% Standard = 20%	Fixed valve setting if no actual value could be received.
Actual value		
<i>Monitoring time</i>	<i>Every min. every 2 min. every 3 min. every 5 min. every 10 min. every 15 min. every 20 min. every 30 min. every 45 min. every 60 min</i>	Only for the <i>External actual value</i> object. If no value is received within the configured time and the object is the only selected source, the emergency program will be activated. As long as at least one valid actual value remains available, this will be continued to be used for control, and the emergency program remains inactive. This is the case if the average value is determined out of 2 or 3 sources.
<i>Send status cyclically</i>	<i>No</i> <i>Only in the event of malfunction</i> <i>always</i>	Send status once on change. Only sends in case of an error, cyclically and in the event of a change: error = 1. The object sends the current status, even if no error is present. Error = 1, no error = 0
<i>Cycle time</i>	<i>every 2 min, every 3 min every 5 min, every 10 min, every 15 min, every 20 min, every 30 min, every 45 min, every 60 min</i>	How often should it be resent?

³⁰ Available if the internal sensor is not selected as the source for the actual value.

4.6.11 Window contact

 If the external input I1 is used as the source for the window contact (see parameter page *RTC/window contact*), the channel *Input I1* is hidden.

Designation	Values	Description
<i>Source for window contact</i>	<i>Via object</i>	Up to 10 objects are available for window contacts. The status of several window contacts can be received via these objects. All objects are connected via an OR link. As soon as one of these objects receives a 1, the window status = window open applies, and frost/heat protection mode is activated.
	<i>External input I1 (direct)</i>	A window contact is connected to the external input I1.
<i>Delay of setpoint switching when opening</i>	<i>no Delay</i>	The frost or heat protection mode is activated immediately when the "Window open" status is detected.
	<i>10 s</i> <i>20 s</i> <i>30 s</i> <i>1 min</i> <i>2 min</i> <i>3 min</i> <i>5 min</i>	Frost or heat protection is not activated until the set time has elapsed. Opening the window for a short time has no effect. When closing the window, the previous mode will immediately be reactivated.
<i>Source for window contact: Via object</i>		
<i>Number of window contacts</i>	<i>1..10</i>	Desired number of window contact objects.
<i>Source for window contact: External input I1 (direct)</i>		
<i>Function I1</i>	Window contact	Set permanently.
<i>Type of connected window contact</i>	Window open = contact closed <i>Window open = contact open</i>	Set the type of connected contact.
<i>Activate block function</i>	no	No block function.
	<i>yes</i>	Show parameters for the block function.
<i>Block telegram</i>	Block with 1 (standard)	0 = cancel block 1 = block
	<i>Block with 0</i>	0 = block 1 = cancel block
<i>Response when the block is set</i>	<i>Ignore block</i>	The block function is ineffective with this telegram.

Designation	Values	Description
	<i>no response</i>	Do not respond when the block is set.
	<i>as with closed window</i>	Respond, as with window status = closed.
	<i>as with open window</i>	Respond, as with window status = open.
<i>Response when cancelling the block</i>	no response	Do not respond when the block is cancelled.
	<i>update</i>	Send update telegram.
Common parameters³¹		
<i>Send window status cyclically</i>	no <i>yes, always</i> <i>only if input = 1</i> <i>only if input = 0</i>	When should cyclical sending take place?
<i>Response after restoration of the bus supply</i>	none <i>update (after approx. 5 s)</i> <i>update (after approx. 10 s)</i> <i>update (after approx. 15 s)</i> <i>update (after approx. 20 s)</i>	Do not send. Send update telegram.

³¹ With *Source for window contact = via object*: Only if more than 1 window contact is used.

4.6.12 Pump control

Designation	Values	Description
<i>Switch-off delay</i>	<i>No switch-off delay</i> <i>2 min, 3 min, 5 min, 7 min, 10 min, 15 min, 20 min, 30 min</i>	Switch off pump immediately continue running for a set length of time.
<i>Switch-on delay</i>	<i>no switch-on delay</i> <i>10 s, 20 s, 30 s, 1 min, 2 min, 3 min, 5 min, 7 min, 10 min</i>	Switch on the pump immediately Only switch on the pump after the delay time has elapsed.
<i>Send pump control cyclically</i>	<i>no, only in the event of change</i> <i>in the event of change and cyclically</i>	How should the current status be sent?
<i>Cycle time</i>	<i>every 2 min, every 3 min every 5 min, every 10 min, every 15 min, every 20 min, every 30 min, every 45 min, every 60 min</i>	At what interval should the switch telegram for the pump be sent?

4.7 Parameters for the actuator

4.7.1 Settings

Designation	Values	Description
<i>Actuator processes actuating value for</i> ³²	Heating <i>Cooling</i> <i>Heating/cooling</i>	Actuator only responds to the heating actuating value Actuator only responds to the cooling actuating value Setting for 2-pipe system when changeover between heating and cooling takes place via object. ³³
<i>Activate valve protection</i>	<i>no</i> Yes	This function prevents the valve from seizing and is executed if the valve position has not changed for 7 days. The valve is moved once over the entire travel path. No valve protection. Valve protection is active.
<i>Time slot</i>	<i>00:00-4:00</i> <i>4:00-8:00</i> <i>8:00-12:00</i> <i>12:00-16:00</i> <i>16:00-20:00</i> <i>20:00-00:00</i>	Time period in which the valve protection function is to be active.  A time/date format must be set. ³⁴
<i>Activate force function</i>	no <i>yes..</i>	No force function. Opens the Force parameter page.
<i>Activate diagnostic messages</i>	no <i>yes..</i>	Only for diagnostics and maintenance. Displays certain diagnostic parameters.

³² Only for heating and cooling mode.

³³ See parameter page **RTC settings**.

³⁴ See **General** parameter page

4.7.2 Actuating value

Designation	Values	Description
<i>Minimum actuating value</i>	0%, 5%, 10%, 20%, 30%	Lowest permissible actuating value
<i>Maximum actuating value</i>	50%, 60%, 70%, 80%, 90%, 100%	Highest permissible actuating value.
<i>Actuating value when value violates the min./max. actuating value³⁵</i>	<p><i>0% or 100%</i></p> <p><i>Use set actuating values</i></p> <p><i>0 = 0%, otherwise use set actuating values</i></p> <p><i>< min. actuating val. = 0%, otherwise scale.</i></p>	<p>Restriction when the controller receives an actuating value that is less than the minimum actuating value:</p> <p>Actuate channel with 0% or 100%</p> <p>Restrict values to maximum and minimum actuating value. For example, maintaining a minimum actuating value of 10% can be practical for the correct base temperature of an underfloor heating.</p> <p>If the received actuating value is = 0, accept this value and close the valve. Other values are restricted according to the configured minimum and maximum actuating value: Received values > 0% and < min. <i>actuating value</i> are replaced by the minimum actuating value. In the same way, values > max. actuating value are replaced by the set maximum actuating value.</p> <p>Actuating values below the minimum actuating value are executed at 0%. Values above are scaled in proportion to the range between min. actuating value and 100%.</p>

³⁵ See appendix: Restriction of actuating value

Designation	Values	Description
<i>Monitor actuating value</i>	no yes..	Only available if the internal room thermostat (RTC) is deactivated (parameter page General) and the actuating value is received via the bus. If this is not received within the configured monitoring time, an emergency program starts.
<i>Send highest actuating value³⁶</i>	Only if own actuating value is greater <i>Send cyclically</i>	Only send the own actuating value if all other actuators have a lower actuating value. The own actuating value is sent cyclically and thus starts a new actuating value comparison.
<i>Cycle time</i>	<i>every 2 min, every 3 min, every 5 min, every 10 min, every 15 min, every 20 min, every 30 min, every 45 min, every 60 min</i>	At what interval should the transmission take place?

³⁶ See appendix: Determining the highest actuating value

4.7.3 Linear valve characteristic

This parameter page only appears if a *linear valve characteristic*³⁷ has been selected on the page **Valve characteristics**

This setting is only to be used for valves that are explicitly marked as linear.

Note: In this table the values are only displayed and cannot be changed.

Designation	Values	Meaning
Valve stroke in % for 10% volume flow (1..99)	10	At 10% valve stroke, a volume flow of 10% is achieved, at 20% valve stroke, a volume flow of 20% is achieved, etc.
Valve stroke in % for 20% volume flow (1..99)	20	
Valve stroke in % for 30% volume flow (1..99)	30	
Valve stroke in % for 40% volume flow (1..99)	40	
Valve stroke in % for 50% volume flow (1..99)	50	
Valve stroke in % for 60% volume flow (1..99)	60	
Valve stroke in % for 70% volume flow (1..99)	70	
Valve stroke in % for 80% volume flow (1..99)	80	
Valve stroke in % for 90% volume flow (1..99)	90	

³⁷ Valve settings = user-defined

4.7.4 Own valve characteristic

Professional setting for special valves.

This parameter page only appears if an *own valve characteristic*³⁸ has been selected on the page **Valve characteristics**.

Using the characteristic curve of the valve (manufacturer's documentation), the behaviour of the actuator can be precisely adjusted here.

This parameter allows KNX Electromotor Valve Control to be adapted to a valve via 9 points of the characteristic curve (10%...90%). It is set for each point at how many % valve stroke a certain flow rate is achieved.

Designation	Values	Meaning
Valve stroke in % for 10% volume flow (1..99)	1..99 (10)	At how many % valve stroke, a volume flow of 10% is achieved?
Valve stroke in % for 20% volume flow (1..99)	1..99 (20)	At how many % valve stroke, a volume flow of 20% is achieved?
Valve stroke in % for 30% volume flow (1..99)	1..99 (30)	At how many % valve stroke, a volume flow of 30% is achieved?
Valve stroke in % for 40% volume flow (1..99)	1..99 (40)	At how many % valve stroke, a volume flow of 40% is achieved?
Valve stroke in % for 50% volume flow (1..99)	1..99 (50)	At how many % valve stroke, a volume flow of 50% is achieved?
Valve stroke in % for 60% volume flow (1..99)	1..99 (60)	At how many % valve stroke, a volume flow of 60% is achieved?
Valve stroke in % for 70% volume flow (1..99)	1..99 (70)	At how many % valve stroke, a volume flow of 70% is achieved?
Valve stroke in % for 80% volume flow (1..99)	1..99 (80)	At how many % valve stroke, a volume flow of 80% is achieved?
Valve stroke in % for 90% volume flow (1..99)	1..99 (90)	At how many % valve stroke, a volume flow of 90% is achieved?

The values in brackets stand for a linear valve.

³⁸ Valve settings = user-defined

4.7.5 Valve characteristics

Designation	Values	Description
<i>Valve settings</i>	Standard	Only the most important parameters are displayed.
	<i>User-defined</i>	Display parameters for valve-specific settings (see below).
Standard parameters		
<i>Move to new valve position</i>	<i>always position exactly</i>	The valve will be repositioned at each change of the actuating value.
	<i>with change of actuating value > 1%</i> <i>with change of actuating value > 2%</i> <i>with change of actuating value > 3%</i> with change of actuating value > 5% <i>with change of actuating value > 7%</i> <i>with change of actuating value > 10%</i> <i>with change of actuating value > 15%</i>	The valve will only be repositioned if the actuating value has changed by more than the set value, compared to the last positioning. This enables frequent, small positioning increments to be suppressed Important: Too high a value can affect the temperature control
<i>Send when valve position changes</i>	when reaching the end position	Only send when the required valve position is reached.
	<i>at change of 1%</i> <i>at change of 2%</i> <i>at change of 3%</i> <i>at change of 5%</i> <i>at change of 7%</i> <i>at change of 10%</i> <i>at change of 15%</i>	New valve position, send at the configured distance, during positioning and when the required valve position is reached.
<i>Cyclically sending of valve position</i>	do not send cyclically <i>every 2 min, every 3 min</i> <i>every 5 min, every 10 min,</i> <i>every 15 min, every 20 min,</i> <i>every 30 min, every 45 min, every 60 min</i>	How should the current valve position be sent?
User-defined parameters		
<i>Direction of action of valve</i>	normal, closed when pressed	for all common valves
	<i>inverted, open when pressed</i>	Adaptation to inverted valves

Designation	Values	Description
<i>Strategy for valve identification</i>	<i>Standard</i>	The valve is closed with a pre-defined force (see below, "Closing force for" parameter). The 0% position is checked at the valve with every run, and the "100% open" position is measured at the valve.
	<i>power-controlled with defined valve stroke</i>	The 0% position is checked at the valve with every run, and the 100% (open) position is determined from the set stroke.
<i>Closing force for</i>	standard valves <i>Valves with high spring tension</i>	This parameter determines the closing force for the 0% position.
<i>Valve stroke</i> ³⁹	2 mm 3 mm 4 mm 5 mm 6 mm 7 mm 8 mm	Here, the traverse from the 0% to the 100 % position is set manually.
<i>Additional pressing of rubber seal</i>	0..0.8 mm in 0.1 mm increments	The set value determines the additional pressing in mm. This allows the valve to be further closed by a set path if, due to the characteristics of the rubber seal, it fails to close completely. Caution: In order to avoid seal damage, the value should be increased by max. 0.1 mm increments.
<i>Type of valve seal</i>	Standard valve seal <i>Valve with hard seal</i> <i>Valve with soft seal</i> <i>Valve with medium-soft seal</i>	This parameter should only be changed if the valve does not open at low actuating values.
<i>Valve characteristic</i>	linear characteristic curve	for high quality valves where the flow is proportional to the travel of the valve tappet.
	<i>own characteristic curve</i>	for special valves with known characteristic curve or for special applications
	typical characteristic curve	for all common valve types

³⁹ For *strategy for valve identification* = *with defined valve stroke*

4.7.6 Emergency program

If the control value is monitored, an emergency program is executed if the control value fails.

Designation	Values	Description
<i>Behaviour during emergency program</i>	<i>Fixed valve position</i>	The valve is moved to a predefined position.
	<i>Continue regulation with internal sensor</i>	The room temperature is controlled to a fixed value by means of the integrated temperature sensor.
<i>Fixed valve position</i>	0..25% Standard = 20%	Fixed valve setting if no actuating value could be received.
<i>Setpoint for emergency program</i>	6..25 °C	Continue to control to this temperature with the internal sensor.
Actuating value		
<i>Monitoring time</i>	<i>Every min, 2 min, 3 min, 5 min, 10 min, 15 min, 20 min, 30 min, 45 min, 60 min</i>	Only for object <i>Approach position</i> . If no actuating value is received within the configured time, the emergency program will be activated.
<i>Send status cyclically</i>	No	Only send in the event of a change.
	<i>Only in the event of malfunction</i>	Only sends in case of an error, cyclically and in the event of a change: error = 1.
	<i>always</i>	The object sends the current status, even if no error is present. Error = 1, no error = 0
<i>Cycle time</i>	<i>every 2 min, every 3 min, every 5 min, every 10 min, every 15 min, every 20 min, every 30 min, every 45 min, every 60 min</i>	How often should it be resent?

4.7.7 Force

Designation	Values	Description
<i>Actuating value in the forced operation</i>	0% to 100% in increments of 10%	Fixed actuating value to control the valve in forced operation. This is not restricted by the minimum or the maximum actuating value.
<i>Forced telegram</i>	1 = Force (standard) <i>0 = Force</i>	Forced operation is activated with an ON telegram. Inverted: Forced operation is activated with an OFF telegram.

4.8 Parameters for external inputs I1, I2

i If the external input I1 is used as the source for the window contact (see parameter page *RTC/window contact*), the channel *Input I1* is hidden.

i If the external input I2 is used as the source for the actual value (see parameter page *RTC/actual value*), the channel *Input I2* is hidden.

4.8.1 Input I1, I2: Switch function

Designation	Values	Description
<i>Function</i>	Switch.. <i>Push button..</i> <i>Dimming..</i> <i>Blinds..</i> <i>Window contact..</i>	Desired use.
<i>Debounce time</i>	<i>30 ms, 50 ms, 80 ms</i> <i>100 ms, 200 ms,</i> <i>1 s, 5 s, 10 s</i>	In order to avoid disruptive switching due to bouncing of the contact connected to the input, the new status of the input is only accepted after a delay time. Larger values (≥ 1 s) can be used as a switch-on delay
<i>Activate block function</i>	no yes	No block function. Show parameters for the block function.
<i>Block telegram</i>	Block with 1 (standard) <i>Block with 0</i>	0 = cancel block 1 = block 0 = block 1 = cancel block
<i>Send cyclically</i>	<i>every min</i> <i>every 2 min, every</i> <i>3 min</i> <i>every 5 min, every</i> <i>10 min,</i> <i>every 15 min, every</i> <i>20 min,</i> every 30 min, every <i>45 min, every 60 min</i>	Common cycle time for all output objects of the channel.
<i>Number of telegrams</i>	one telegram <i>two telegrams</i>	Each channel has 2 output objects and can thus send up to 2 different telegrams.

4.8.1.1 Switch objects 1, 2

Each of the 2 objects can be configured individually on its own parameter page.

Designation	Values	Description	
<i>Object type</i>	Switching (1 bit) <i>Priority (2 bit)</i> <i>Value 0-255</i> <i>Percentage value (1 byte)</i>	Telegram type for this object.	
<i>Send if input = 1</i>	<i>no</i> yes	Send with rising edge.	
<i>Telegram</i>	<i>With object type = switching</i> 1 bit		
	ON <i>OFF</i> <i>Changeover</i>	Send switch-on command Send switch-off command Invert current state (ON-OFF-ON etc.)	
	<i>With object type = priority 2 bit</i>		
	No priority <i>Priority ON</i> <i>Priority OFF</i>	Function	Value
		Priority inactive (no control)	0 (00 _{bin})
		Priority ON (control: enable, on)	3 (11 _{bin})
	Priority OFF (control: disable, off)	2 (10 _{bin})	
	<i>With object type = value 0-255</i>		
	0-255	Any value between 0 and 255 can be sent.	
	<i>With object type = percentage value 1 byte</i>		
0-100%	Any percentage value between 0 and 100% can be sent.		
<i>Send if input = 0</i>	<i>no</i> yes	Send with falling edge.	
<i>Telegram</i>	See above: Same object type as <i>Send if input = 1</i>		
<i>Send cyclically</i>	no <i>yes, always</i> <i>only if input = 1</i> <i>only if input = 0</i>	When should cyclical sending take place? The cycle time is set on the Configuration options parameter page.	
<i>Response after restoration of the bus supply</i>	none	Do not send.	
	<i>update (after approx. 5 s)</i>	Send update telegram.	
	<i>update (after approx. 10 s)</i>		
	<i>update (after approx. 15 s)</i>		
	<i>update (after approx. 20 s)</i>		
<i>Response when the block is set</i>	Ignore block	The block function is ineffective with this telegram. Do not respond when the block is set. Respond as with rising edge. Respond as with falling edge.	
	<i>no response</i>		
	<i>As with input = 1</i>		
	<i>As with input = 0</i>		
<i>Response when cancelling the block</i>	no response	Do not respond when the block is cancelled. Send update telegram.	
	<i>update</i>		



If a channel is blocked, no telegrams will be sent cyclically.

4.8.2 Input I1, I2: Push button function

Designation	Values	Description
<i>Function</i>	<i>Switch..</i> <i>Push button..</i> <i>Dimming..</i> <i>Blinds..</i> <i>Window contact..</i>	Desired use.
<i>Debounce time</i>	<i>30 ms, 50 ms, 80 ms</i> <i>100 ms, 200 ms</i>	In order to avoid disruptive switching due to bouncing of the contact connected to the input, the new status of the input is only accepted after a delay time.
<i>Connected button</i>	NO contact <i>NC contact</i>	Set the type of connected contact.
<i>Long button push starting at</i>	300 ms, 400 ms <i>500 ms, 600 ms</i> <i>700 ms, 800 ms</i> <i>900 ms, 1 s</i>	Serves to clearly differentiate between long and short button push. If the button is pressed for at least as long as the set time, then a long button push will be registered.
<i>Time for double-click</i>	300 ms, 400 ms <i>500 ms, 600 ms</i> <i>700 ms, 800 ms</i> <i>900 ms, 1 s</i>	Serves to differentiate between a double-click and 2 single clicks. Time period in which the second click must begin, in order to recognise a double-click.
<i>Send cyclically</i>	<i>every min</i> <i>every 2 min, every</i> <i>3 min</i> <i>every 5 min, every</i> <i>10 min,</i> <i>every 15 min, every</i> <i>20 min,</i> every 30 min, every <i>45 min, every 60 min</i>	Common cycle time for all 2 output objects of the channel.
<i>Number of telegrams</i>	one telegram <i>two telegrams</i>	Each channel has 2 output objects and can thus send up to 2 different telegrams.
<i>Activate block function</i>	no <i>yes</i>	No block function. Show parameters for the block function.
<i>Block telegram</i>	Block with 1 (standard) <i>Block with 0</i>	0 = cancel block 1 = block 0 = block 1 = cancel block

4.8.2.1 Push button objects 1, 2

Designation	Values	Description	
<i>Object type</i>	Switching (1 bit) <i>Priority (2 bit)</i> <i>Value 0-255</i> <i>Percentage value (1 byte)</i>	Telegram type for this object.	
<i>Send after short operation</i>	<i>do not send</i> Send telegram	Respond to short button push?	
<i>Telegram</i>	<i>With object type = switching 1 bit</i>		
	ON <i>OFF</i> <i>Changeover</i>	Send switch-on command Send switch-off command Invert current state (ON-OFF-ON etc.)	
	<i>With object type = priority 2 bit</i>		
	No priority <i>Priority ON</i> <i>Priority OFF</i>	Function	Value
		Priority inactive (no control)	0 (00 _{bin})
		Priority ON (control: enable, on)	3 (11 _{bin})
	Priority OFF (control: disable, off)	2 (10 _{bin})	
	<i>With object type = value 0-255</i>		
	0-255	Any value between 0 and 255 can be sent.	
	<i>With object type = percentage value 1 byte</i>		
0-100%	Any percentage value between 0 and 100% can be sent.		
<i>Send after long operation</i>	do not send <i>Send telegram</i>	Each button push is treated as a short button push. After a long button push, the telegram configured for this purpose is sent.	
<i>Telegram</i>	See above: Same object type as with short operation.		
<i>Send after double-click</i>	do not send <i>Send telegram</i>	No double-click function. Double clicks are treated as 2 single clicks. After double-click, the telegram configured for this purpose is sent.	
<i>Telegram</i>	See above: Same object type as with short operation.		
<i>Send cyclically</i>	no <i>yes</i>	The cycle time is set on the Configuration options parameter page.	
	none	Do not send.	

Designation	Values	Description
<i>Response after restoration of the bus supply</i>	<i>as after short (after approx. 5 s)</i> <i>as after short (after approx. 10 s)</i> <i>as after short (after approx. 15 s)</i> <i>as after short (after approx. 20 s)</i> <i>as after long (after approx. 5 s)</i> <i>as after long (after approx. 10 s)</i> <i>as after long (after approx. 15 s)</i> <i>as after long (after approx. 20 s)</i> <i>as with double-click (after approx. 5 s)</i> <i>as with double-click (after approx. 10 s)</i> <i>as with double-click (after approx. 15 s)</i> <i>as with double-click (after approx. 20 s)</i>	Send update telegram.
<i>Response when the block is set</i>	Ignore block <i>no response</i> <i>As with short</i> <i>as with long</i> <i>as with double-click</i>	The block function is ineffective with this telegram. Do not respond when the block is set. Respond as with a short button push. Respond as with a long button push. Respond as with a double-click.
<i>Response when cancelling the block</i>	no response <i>As with short</i> <i>as with long</i> <i>as with double-click</i>	Do not respond when the block is cancelled. Respond as with a short button push. Respond as with a long button push. Respond as with a double-click.

4.8.3 Input I1, I2: Dimming function

Designation	Values	Description
<i>Channel function</i>	<i>Switch..</i> <i>Push button..</i> <i>Dimming..</i> <i>Blinds..</i> <i>Window contact..</i>	The input controls a dimming actuator
<i>Debounce time</i>	<i>30 ms, 50 ms, 80 ms</i> <i>100 ms, 200 ms,</i>	In order to avoid disruptive switching due to bouncing of the contact connected to the input, the new status of the input is only accepted after a delay time.
<i>Activate block function</i>	<i>no</i> <i>yes</i>	No block function. Show block function parameter page.
<i>Block telegram</i>	<i>Block with 1 (standard)</i> <i>Block with 0</i>	0 = cancel block 1 = block 0 = block 1 = cancel block
<i>Long button push starting at</i>	<i>300 ms, 400 ms</i> <i>500 ms, 600 ms</i> <i>700 ms, 800 ms</i> <i>900 ms, 1 s</i>	Serves to clearly differentiate between long and short button push. If the button is pressed for at least as long as the set time, then a long button push will be registered.
<i>Double-click additional function</i>	<i>no</i> <i>yes</i>	No double-click function The <i>double-click</i> parameter page is shown.
<i>Time for double-click</i>	<i>300 ms, 400 ms</i> <i>500 ms, 600 ms</i> <i>700 ms, 800 ms</i> <i>900 ms, 1 s</i>	Serves to differentiate between a double-click and 2 single clicks. Time period in which the second click must begin, in order to recognise a double-click.

4.8.3.1 Dimming parameter page

Designation	Values	Description
<i>Response to long/short</i>	<p>One button operation</p> <p><i>Brighter / ON</i></p> <p><i>brighter / change over</i></p> <p><i>darker / OFF</i></p> <p><i>darker / change over</i></p>	<p>The input distinguishes between a long and a short button push, and can thus carry out 2 functions.</p> <p>The dimmer is operated with a single button. Short button push = ON/OFF Long button push = brighter/darker release = stop</p> <p>With the other variants, the dimmer is operated using 2 buttons (rocker).</p> <p>Short button push = ON Long button push = brighter Release = stop</p> <p>Short button push = ON / OFF Long button push = brighter Release = stop</p> <p>Short button push = OFF Long button push = darker Release = stop</p> <p>Short button push = ON / OFF Long button push = darker Release = stop</p>
<i>Increment for dimming</i>	<p>100%</p> <p>50%</p> <p>25%</p> <p>12.5%</p> <p>6%</p> <p>3%</p> <p>1.5%</p>	<p>With a long button push, the dimming value is:</p> <p>Increased (or decreased) until the button is released.</p> <p>Increased by the selected value (or reduced)</p>
<i>Response after restoration of the bus supply</i>	<p>none</p> <p><i>after approx. 5 s On</i></p> <p><i>after approx. 10 s On</i></p> <p><i>after approx. 15 s On</i></p> <p><i>after approx. 20 s On</i></p>	<p>Do not respond.</p> <p>Switch on dimmer</p>

Designation	Values	Description
	<i>after approx. 5 s Off</i> <i>after approx. 10 s Off</i> <i>after approx. 15 s Off</i> <i>after approx. 20 s Off</i>	Switch off dimmer
<i>Response when the block is set</i>	Ignore block <i>no response</i> <i>ON</i> <i>OFF</i>	The block function is ineffective with this telegram. Do not respond when the block is set. Switch on dimmer Switch off dimmer
<i>Response when cancelling the block</i>	no response <i>ON</i> <i>OFF</i>	Do not respond when the block is cancelled. Switch on dimmer Switch off dimmer

4.8.3.2 Double-click parameter page

Designation	Values	Description	
<i>Object type</i>	Switching (1 bit) <i>Priority (2 bit)</i> <i>Value 0-255</i> <i>Percentage value (1 byte)</i>	Telegram type for this object.	
<i>Telegram</i>	With object type = switching 1 bit		
	ON <i>OFF</i> <i>Changeover</i>	Send switch-on command Send switch-off command Invert current state (ON-OFF-ON etc.)	
	With object type = priority 2 bit		
	No priority <i>Priority ON</i> <i>Priority OFF</i>	Function	Value
		Priority inactive (no control)	0 (00 _{bin})
		Priority ON (control: enable, on)	3 (11 _{bin})
	Priority OFF (control: disable, off)	2 (10 _{bin})	
	With object type = value 0-255		
	0-255	Any value between 0 and 255 can be sent.	
	With object type = percentage value 1 byte		
0-100%	Any percentage value between 0 and 100% can be sent.		
<i>Send cyclically</i>	do not send cyclically <i>every min,</i> <i>every 2 min, every 3 min</i> <i>every 5 min, every 10 min,</i> <i>every 15 min, every 20 min,</i> every 30 min, <i>every 45 min,</i> <i>every 60 min</i>	How often should it be resent?	
<i>Response after restoration of the bus supply</i>	none <i>as with double-click (after approx. 5 s)</i> <i>as with double-click (after approx. 10 s)</i> <i>as with double-click (after approx. 15 s)</i> <i>as with double-click (after approx. 20 s)</i>	Do not send. Send update telegram.	
<i>Response when the block is set</i>	Ignore block <i>no response</i> <i>as with double-click</i>	The block function is ineffective with this telegram. Do not respond when the block is set. Respond as with a double-click.	

Designation	Values	Description
<i>Response when cancelling the block</i>	<i>no response</i>	Do not respond when the block is cancelled.
	<i>as with double-click</i>	Respond as with a double-click.

4.8.4 Input I1, I2: Blinds function

Designation	Values	Description
<i>Channel function</i>	<i>Switch..</i> <i>Push button..</i> <i>Dimming..</i> <i>Blinds..</i> <i>Window contact..</i>	The input controls a blind actuator.
<i>Debounce time</i>	<i>30 ms, 50 ms, 80 ms</i> <i>100 ms, 200 ms</i>	In order to avoid disruptive switching due to bouncing of the contact connected to the input, the new status of the input is only accepted after a delay time.
<i>Activate block function</i>	<i>no</i> <i>yes</i>	No block function. Show block function parameter page.
<i>Block telegram</i>	<i>Block with 1</i> <i>(standard)</i> <i>Block with 0</i>	0 = cancel block 1 = block 0 = block 1 = cancel block
<i>Long button push starting at</i>	<i>300 ms, 400 ms</i> <i>500 ms, 600 ms</i> <i>700 ms, 800 ms</i> <i>900 ms, 1 s</i>	Serves to clearly differentiate between long and short button push. If the button is pressed for at least as long as the set time, then a long button push will be registered.
<i>Double-click additional function</i>	<i>no</i> <i>yes</i>	No double-click function The double-click parameter page is shown.
<i>Time for double-click</i>	<i>300 ms, 400 ms</i> <i>500 ms, 600 ms</i> <i>700 ms, 800 ms</i> <i>900 ms, 1 s</i>	Serves to differentiate between a double-click and 2 single clicks. Time period in which the second click must begin, in order to recognise a double-click.

4.8.4.1 Blinds parameter page

Designation	Values	Description
<i>Operation</i>	<p>One button operation</p> <p><i>DOWN</i></p> <p><i>UP</i></p>	<p>The input distinguishes between a long and a short button push, and can thus carry out 2 functions.</p> <p>The blinds are operated with a single button. Short button push = step. Long button push = move.</p> <p>Short button push = step. Long button push = lower.</p> <p>Short button push = step. Long button push = raise.</p>
<i>Movement is stopped by</i>	<i>Releasing the button</i> Short operation	How is the stop command to be triggered?
<i>Response after restoration of the bus supply</i>	<p>none</p> <p><i>UP</i></p> <p><i>DOWN</i></p> <p><i>UP after 5 s</i> <i>UP after 10 s</i> <i>UP after 15 s</i></p> <p><i>DOWN after 5 s</i> <i>DOWN after 10 s</i> <i>DOWN after 15 s</i></p>	<p>Do not respond.</p> <p>Raise blinds</p> <p>Lower blinds</p> <p>Raise blinds with delay</p> <p>Lower blinds with delay</p>
<i>Response when the block is set</i>	<p>Ignore block</p> <p><i>no response</i></p> <p><i>UP</i></p> <p><i>DOWN</i></p>	<p>The block function is ineffective with this telegram.</p> <p>Do not respond when the block is set.</p> <p>Raise blinds</p> <p>Lower blinds</p>
<i>Response when cancelling the block</i>	<p>no response</p> <p><i>UP</i></p> <p><i>DOWN</i></p>	<p>Do not respond when the block is cancelled.</p> <p>Raise blinds</p> <p>Lower blinds</p>

4.8.4.2 Double-click parameter page

Designation	Values	Description									
<i>Object type</i>	Switching (1 bit) <i>Priority (2 bit)</i> <i>Value 0-255</i> <i>Percentage value (1 byte)</i> <i>Height % + slat %</i>	Telegram type for this object.									
<i>Telegram</i>	With object type = switching 1 bit										
	ON <i>OFF</i> <i>Changeover</i>	Send switch-on command Send switch-off command Invert current state (ON-OFF-ON etc.)									
	With object type = priority 2 bit										
	No priority <i>Priority ON</i> <i>Priority OFF</i>	<table border="1"> <thead> <tr> <th>Function</th> <th>Value</th> </tr> </thead> <tbody> <tr> <td>Priority inactive (no control)</td> <td>0 (00_{bin})</td> </tr> <tr> <td>Priority ON (control: enable, on)</td> <td>3 (11_{bin})</td> </tr> <tr> <td>Priority OFF (control: disable, off)</td> <td>2 (10_{bin})</td> </tr> </tbody> </table>	Function	Value	Priority inactive (no control)	0 (00 _{bin})	Priority ON (control: enable, on)	3 (11 _{bin})	Priority OFF (control: disable, off)	2 (10 _{bin})	
		Function	Value								
		Priority inactive (no control)	0 (00 _{bin})								
	Priority ON (control: enable, on)	3 (11 _{bin})									
	Priority OFF (control: disable, off)	2 (10 _{bin})									
	With object type = value 0-255										
	0-255	Any value between 0 and 255 can be sent.									
With object type = percentage value 1 byte											
0-100%	Any percentage value between 0 and 100% can be sent.										
With object type = height % + slat %											
<i>Height</i>	Upon double-click 2 telegrams are sent simultaneously: Required blind height										
<i>Slat</i>	Required slat position.										
<i>Send cyclically</i>	do not send cyclically <i>every min</i> <i>every 2 min, every 3 min</i> <i>every 5 min, every 10 min,</i> <i>every 15 min, every 20 min,</i> <i>every 30 min, every 45 min,</i> <i>every 60 min</i>	How often should it be resent?									
<i>Response after restoration of the bus supply</i>	none <i>as with double-click (after approx. 5 s)</i> <i>as with double-click (after approx. 10 s)</i> <i>as with double-click (after approx. 15 s)</i> <i>as with double-click (after approx. 20 s)</i>	Do not send. Send update telegram.									

Designation	Values	Description
<i>Response when the block is set</i>	<i>Ignore block</i>	The block function is ineffective with this telegram.
	<i>no response</i>	Do not respond when the block is set.
	<i>as with double-click</i>	Respond as with a double-click.
<i>Response when cancelling the block</i>	<i>no response</i>	Do not respond when the block is cancelled.
	<i>as with double-click</i>	Respond as with a double-click.

4.8.5 Input I1, I2: window contact function

Designation	Values	Description
<i>Function</i>	<i>Switch..</i> <i>Push button..</i> <i>Dimming..</i> <i>Blinds..</i> Window contact..	Desired use.
<i>Debounce time</i>	<i>30 ms, 50 ms, 80 ms</i> <i>100 ms, 200 ms,</i> <i>1 s, 5 s, 10 s</i>	In order to avoid disruptive switching due to bouncing of the contact connected to the input, the new status of the input is only accepted after a delay time. Larger values (≥ 1 s) can be used as a delay.
<i>Send cyclically</i>	<i>every min</i> <i>every 2 min, every</i> <i>3 min</i> <i>every 5 min, every</i> <i>10 min,</i> <i>every 15 min, every</i> <i>20 min,</i> <i>every 30 min, every</i> <i>45 min,</i> <i>every 60 min</i>	Cycle time.
<i>Activate block function</i>	no <i>yes</i>	No block function. Show parameters for the block function.
<i>Block telegram</i>	Block with 1 (standard) <i>Block with 0</i>	0 = cancel block 1 = block 0 = block 1 = cancel block

4.8.5.1 Window contact

Designation	Values	Description
<i>Telegram when contact closed</i>	On Off	Set switching status.
<i>Telegram when contact open</i>	<i>On</i> Off	Is set automatically.
<i>Send cyclically</i>	no <i>yes, always</i> <i>only if input = 1</i> <i>only if input = 0</i>	When should cyclical sending take place? The cycle time is set on the Configuration options parameter page.
<i>Response after restoration of the bus supply</i>	none <i>as with double-click (after approx. 5 s)</i> <i>as with double-click (after approx. 10 s)</i> <i>as with double-click (after approx. 15 s)</i> <i>as with double-click (after approx. 20 s)</i>	Do not send. Send update telegram.
<i>Response when the block is set</i>	Ignore block <i>no response</i> <i>As with input = 1</i> <i>As with input = 0</i>	The block function is ineffective with this telegram. Do not respond when the block is set. Respond as with rising edge. Respond as with falling edge.
<i>Response when cancelling the block</i>	no response <i>update</i>	Do not respond when the block is cancelled. Send update telegram.

4.8.6 Input I2: Temperature input function⁴⁰

Designation	Values	Description
<i>Channel function</i>	<i>Switch..</i> <i>Push button..</i> <i>Dimming..</i> <i>Blinds..</i> Temperature input	The input is connected to a temperature sensor
<i>Temperature calibration</i>	- 5 K.. +5 K (resolution 0.1 K)	Correction value for temperature measurement if sent temperature deviates from the actual ambient temperature. Example: temperature = 21 °C sent temperature = 20.5 °C Correction value = 0.5 K
<i>Send actual value in the event of change of</i>	<i>not due to a change</i>	Only send cyclically (if enabled)
	0.2 K 0.3 K 0.5 K 0.7 K 1 K 1.5 K 2 K	Send if the value has changed by the selected amount since the last transmission.
<i>Send actual value cyclically</i>	do not send cyclically <i>every min,</i> <i>every 2 min, every</i> <i>3 min</i> <i>every 5 min, every</i> <i>10 min,</i> <i>every 15 min, every</i> <i>20 min,</i> <i>every 30 min, every</i> <i>45 min,</i> <i>every 60 min</i>	How often should the current measured value be resent?

-
-  **Applicable sensor types:**
temperature sensor UP (9070496)
remote sensor IP65 (9070459)
floor sensor (9070321)
-

⁴⁰ The temperature input function is only possible with input I2.

5 Start-up

5.1 Connection



Warning of electric shock on the KNX installation.



Do not connect any external voltage to the inputs (SELV).



Ensure separation from other voltages.



Only use the device with the cover closed.

This is the only way to ensure reliable fixation and the required IP protection.



If maintenance work is carried out on the radiator, the actuator should always be removed and the valve securely closed by an alternative method (original protective cap etc.). The valve could be opened unexpectedly by the control or by the valve protection, resulting in water damage.



When downloading the application, KNX Electromotor Valve Control must already be mounted on the valve, otherwise no adjustment can take place

5.2 Installation

Open the cover (loosen the screw if necessary).
Move the red slider down. The lock opens.
Plug the device on the valve (adapter).
Move the red slider up and close the cover.

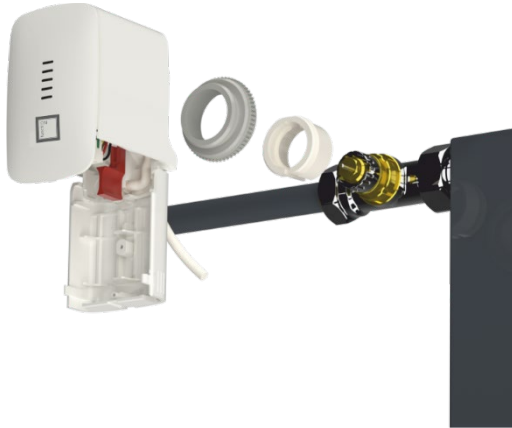

5.3 Installation and automatic adjustment (calibration traverse)

First, the device is mounted on the valve using the appropriate adapter ring (see above).
Then the bus voltage can be applied.
This automatically starts the adjustment process (calibration traverse).

When does the adjustment process occur?
Automatic adjustment occurs for the first time after the bus voltage is applied in the Site function, and afterwards each time the application is downloaded.

To compensate for changes in the valve characteristics over time (ageing of the rubber seal), a new calibration traverse is carried out after each reset and at regular intervals during the heating period. Also, a new calibration traverse can be started at any time via the Maintenance object.

i The adjustment must always be carried out again if a device that has already been adjusted is mounted on a different valve.

i The previously stored positions are deleted after a download.
The calibration traverse is performed 2x due to the plausibility test.

5.4 Calibration strategies

The selection of the calibration strategy is made via input in the *Strategy for valve identification* parameter

5.4.1 Standard

With this option, only the "Open" valve position is determined during the calibration traverse. To close the valve, the actuator extends the tappet until it presses on the valve with the set force.

It is always recommended to use the *standard valve* setting first, as it is completely sufficient for most valves.

The *valves with high spring tension* setting should only be tried if it is not possible to close the valve.

5.4.2 Power-controlled with defined valve stroke

With this variant, only the Open position of the valve is determined by calculating a fixed distance back from the closed position. In order to close the valve, the actuator pushes out the tappet until the set force is exerted on the valve (closing force for standard valves/valves with high spring tension).

This calibration strategy is primarily to be used if the actuator tappet touches the valve tappet, even if it is completely withdrawn, and measurements cannot be performed.

With a completely unknown valve, a value of 3 mm with closing force for standard valves value is a useful starting value.

It is always recommended to use the closing force for standard valves first.

This setting is quite sufficient for most valves.

Only if this does not close the valve, the setting for valves with high spring force should be tried.

5.4.3 LED display during calibration traverse

LEDs	Behaviour
<div style="display: flex; flex-direction: column; align-items: center;"> <div style="border: 1px solid black; width: 20px; height: 20px; display: flex; align-items: center; justify-content: center; margin-bottom: 2px;">4</div> <div style="border: 1px solid black; width: 20px; height: 20px; display: flex; align-items: center; justify-content: center; margin-bottom: 2px;">3</div> <div style="border: 1px solid black; width: 20px; height: 20px; display: flex; align-items: center; justify-content: center; margin-bottom: 2px;">2</div> <div style="border: 1px solid black; width: 20px; height: 20px; display: flex; align-items: center; justify-content: center; margin-bottom: 2px;">1</div> <div style="border: 1px solid black; width: 20px; height: 20px; display: flex; align-items: center; justify-content: center; background-color: yellow;">0</div> </div>	Flashes as long as the spindle is in its maximum inner position
<div style="display: flex; flex-direction: column; align-items: center;"> <div style="border: 1px solid black; width: 20px; height: 20px; display: flex; align-items: center; justify-content: center; margin-bottom: 2px;">4</div> <div style="border: 1px solid black; width: 20px; height: 20px; display: flex; align-items: center; justify-content: center; margin-bottom: 2px;">3</div> <div style="border: 1px solid black; width: 20px; height: 20px; display: flex; align-items: center; justify-content: center; margin-bottom: 2px;">2</div> <div style="border: 1px solid black; width: 20px; height: 20px; display: flex; align-items: center; justify-content: center; background-color: yellow; margin-bottom: 2px;">1</div> <div style="border: 1px solid black; width: 20px; height: 20px; display: flex; align-items: center; justify-content: center; margin-bottom: 2px;">0</div> </div>	Flashes while valve is scanned
<div style="display: flex; flex-direction: column; align-items: center;"> <div style="border: 1px solid black; width: 20px; height: 20px; display: flex; align-items: center; justify-content: center; margin-bottom: 2px;">4</div> <div style="border: 1px solid black; width: 20px; height: 20px; display: flex; align-items: center; justify-content: center; margin-bottom: 2px;">3</div> <div style="border: 1px solid black; width: 20px; height: 20px; display: flex; align-items: center; justify-content: center; background-color: yellow; margin-bottom: 2px;">2</div> <div style="border: 1px solid black; width: 20px; height: 20px; display: flex; align-items: center; justify-content: center; margin-bottom: 2px;">1</div> <div style="border: 1px solid black; width: 20px; height: 20px; display: flex; align-items: center; justify-content: center; margin-bottom: 2px;">0</div> </div>	Flashes during position calculation (can be very brief)

5.5 Site function

As long as the device is in its initial delivery condition, i.e. as long as no application has been loaded, the KNX Electromotor Valve Control functions in site mode.

This means that the KNX Electromotor Valve Control can already keep the room frost-free (6 °C) during the time between installation and start-up by a KNX system integrator.

5.6 Valves and valve seals

5.6.1 Valve design

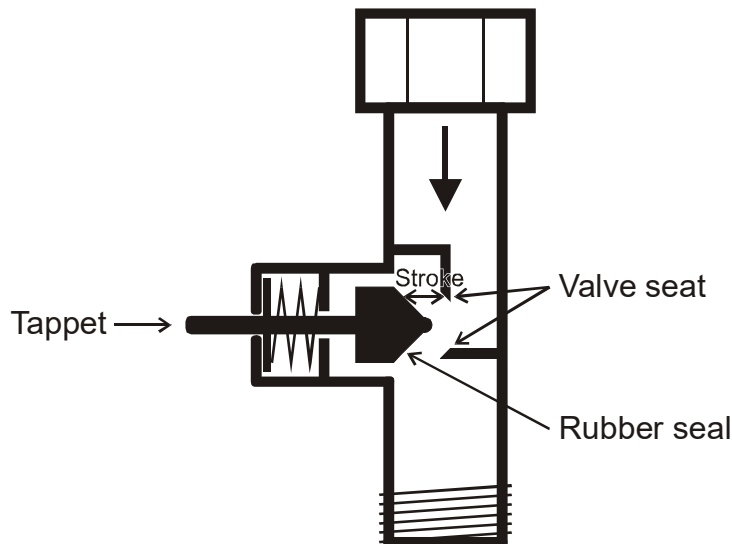

5.6.2 Valves and valve seals

In the idle state, i.e. when the tappet is not actuated, it is pressed outwards by the spring and the valve is open (100% position with normal direction of action).

When the tappet is pressed, the rubber seal is pressed into the valve seat and the valve is closed (0% position with normal direction of action).

The valve does not close immediately when the rubber seal touches the valve seat, the tappet may have to travel several 1/10 mm further until the valve is actually closed, depending on the characteristics of the seal.

This behaviour is determined by the hardness, shape, ageing, or any damage of the valve seal.

To correct the influence of these parameters, an additional pressure of the valve seal can be entered for KNX Electromotor Valve Control.

i Caution: In order to avoid seal damage, the value should be increased by max. 1/100 mm increments.

6 Appendix

6.1 Determining the current operating mode

The current setpoint can be adjusted to the relevant requirements by selecting the operating mode.

The operating mode can be specified via the objects *operating mode preset*, *presence*, and *window setting*.

The current operating mode can be specified as follows:

Object <i>Operating mode preset</i>	Object <i>Presence</i>	Object <i>Window setting</i>	current operating mode
any	any	1	Frost/heat protection
any	1	0	Comfort
Comfort	0	0	Comfort
Standby	0	0	Standby
Night	0	0	Night
Frost/heat protection	0	0	Frost/heat protection

6.2 Priorities for operating mode selection

In principle the following applies: The last instruction overwrites the previous one.

ⓘ Exception: Frost mode via window contact has priority in all operating modes.

Upon selection of the *presence button* parameter, the following also applies:

If a new operating mode is received on the object with the presence object set (*operating mode preset*), it will be accepted and the presence object will be reset (only with presence button).

Reception of the same operating mode as prior to the presence status (e.g. via cycl. sending) is ignored.

If the *presence object* is set during night/frost mode, it will be reset after the configured comfort extension finishes.

If the *presence object* is set during standby mode, the comfort operating mode is accepted without time restriction.

Determining the operating mode when using a presence detector

Specifying the operating mode via..

Object *Operating mode preset*
Operating mode after download

Last command applies

Results in..

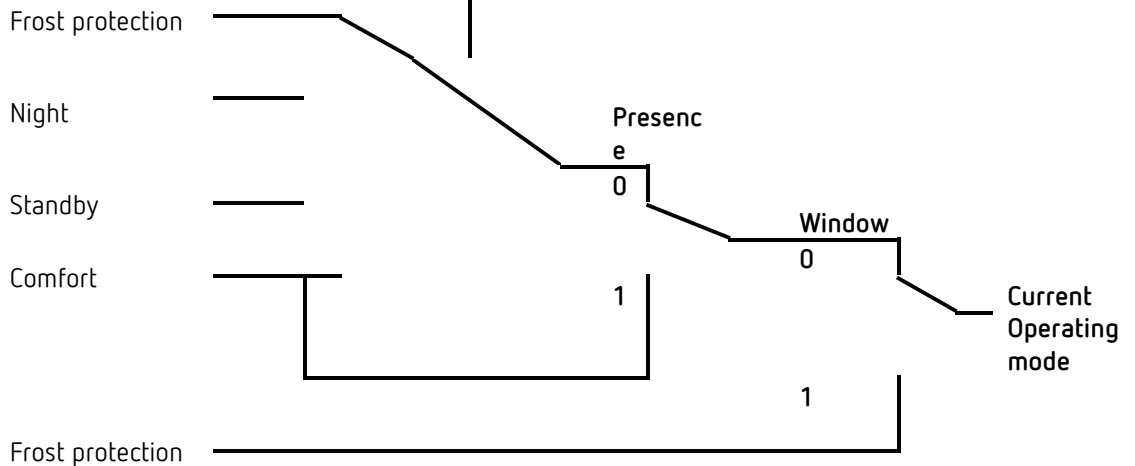

6.3 Base setpoint and current setpoint

The **base setpoint** is the standard temperature for comfort mode and the reference temperature for reduction in standby and night modes.

The programmed base setpoint (see *base setpoint after downloading the application*) is stored in object *base setpoint* and can be changed via the bus at any time.

The **current setpoint** is the setpoint that is actually used for control. It is the result of all the reductions or increases associated with the operating mode and control function.

Example:

At a base setpoint of 22 °C and a reduction in night mode of 4 K, the current setpoint (in night mode) is: $22\text{ °C} - 4\text{ K} = 18\text{ °C}$.

During the day (in comfort mode), the current setpoint is 22 °C (provided that cooling mode is not active).

The current setpoint depends on the operating mode and on the selected control function.

If the setpoint, because of a setpoint offset, is outside the programmed values for frost and heat protection, it is restricted to these values by the safety limits.

6.4 Determination of the setpoint

6.4.1 Setpoint calculation in heating mode

Current setpoint during heating

Operating mode	Current setpoint
Comfort	Base setpoint +/- setpoint offset
Standby	Base setpoint +/- setpoint offset – reduction in standby mode
Night	Base setpoint +/- setpoint offset – reduction in night mode
Frost/heat protection	Configured setpoint for frost protection mode

Example:

Heating in comfort mode.

Parameter page	Parameters	Setting
Setpoints	<i>Base setpoint after loading the application</i>	21 °C
	<i>Reduction in standby mode (during heating)</i>	2 K
	<i>Maximum valid setpoint offset</i>	+/- 2 K

The setpoint was previously increased by 1 K via object *setpoint offset*.

Calculation:

Current setpoint
 = base setpoint + setpoint offset
 = 21 °C + 1 K
 = 22 °C

If operation is switched to standby mode, the current setpoint is calculated as follows:

Current setpoint
 = base setpoint + setpoint offset – reduction in standby mode
 = 21 °C + 1 K – 2 K
 = 20 °C

6.4.2 Setpoint calculation in cooling mode

Current setpoint during cooling

Operating mode	Current setpoint
Comfort	Base setpoint + setpoint offset + dead zone
Standby	Base setpoint + setpoint offset + dead zone + increase in standby mode
Night	Base setpoint + setpoint offset + dead zone + increase in night mode
Frost/heat protection	Configured setpoint for heat protection mode

Example:

Cooling in comfort mode.

The room temperature is too high, the controller has switched to cooling mode

Parameter page	Parameters	Setting
Setpoints	<i>Base setpoint after loading the application</i>	21 °C
	<i>Maximum valid setpoint offset</i>	+/- 2 K
Cooling setpoints	<i>Dead zone between heating and cooling</i>	2 K
	<i>Increase in standby mode (during cooling)</i>	2 K

The setpoint was previously lowered via object *setpoint offset* by 1 K.

Calculation:

Current setpoint
 = base setpoint + setpoint offset + dead zone
 = 21 °C – 1 K + 2 K
 = 22 °C

Changing to standby mode causes a further increase of the setpoint (energy saving), which results in the following setpoint:

Setpoint
 = base setpoint + setpoint offset + dead zone + increase in standby mode
 = 21 °C – 1 K + 2 K + 2 K
 = 24 °C

6.5 Setpoint offset

The current setpoint can be adjusted via object *manual setpoint offset*.
In this case, the setpoint is changed by sending the desired offset to the object.
For this, the difference (may be preceded by a minus sign) is sent as DPT 9.002 to the object *manual setpoint offset*.

The offset limits are defined on the **Heating setpoints** parameter page via the *Maximum valid setpoint offset* parameter.

The offset is always in relation to the Base setpoint and not to the current setpoint.

Example Base setpoint of 21 °C:

If a value of 2 is received by object *manual setpoint offset*, the new setpoint is calculated as follows:

$$21\text{ °C} + 2\text{ K} = 23\text{ °C}$$

In order to afterwards bring the setpoint to 22 °C, the difference to the programmed base setpoint (here 21 °C) is resent, in this case 1 K (21 °C + 1 K = 22 °C)

6.6 Dead zone

The dead zone is a buffer area between heating and cooling mode.
Within this dead zone, neither heating nor cooling occurs.

Without this buffer area, the system would permanently switch between heating and cooling. As soon as the setpoint was fallen below, the heating would be activated. After hardly reaching the setpoint, the cooling would immediately start, the temperature would fall below the setpoint and switch on the heating again.

Heating and cooling with continuous control

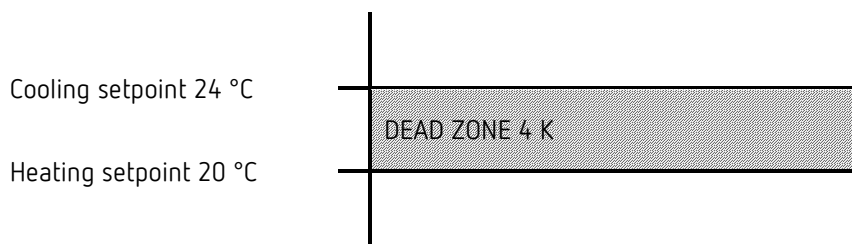

i In a 2-pipe system, the dead zone can be set to 0 K.

6.7 Valve protection

This function prevents the valve from seizing and is executed if the valve position has not changed for 7 days. The valve is completely opened once and closed again, and then the current position is approached again.

6.8 Determining the highest actuating value

6.8.1 Application

If in a system all actuators are opened only slightly, e.g. one at 5%, one at 12%, another at 7% etc., the boiler could decrease its output, because not much heating energy is needed. In order to do so, the boiler has to be informed about the actual energy demand of the system. This task is implemented via the highest actuating value.

 This highest actuating value can also be used to control the flow pump (see below: Actuating value dependent pump control).

6.8.2 Principle

The heating actuators and actuators (KNX Electromotor Valve Control, HU1, HMT 6 S/HMT 12 S devices) are constantly compared with each other. Those participants with a higher actuating value than the other heating actuators may send it; those with a smaller one do not send. In order to accelerate this process: The greater the difference between its own and the received actuating value, the greater the speed at which the heating actuator sends. Thus, the actuator with the highest actuating value sends first and outperforms all others.

6.8.3 In practice

The actuating value comparison takes place via the objects *Highest actuating value (send or receive)*.

For this purpose, all heating actuators are connected via these objects with a common group address.

In order to start the actuating value comparison among the participants, one of the participants must send its actuating value to this group address cyclically.

This task can be performed either by the boiler, or by one of the heating actuators.

If it is the boiler, it must send the minimum possible value, i.e. 0%.

If it is one of the heating actuators, the parameter *Send highest actuating value* must be set to *send cyclically*.

This actuator then regularly sends its own actuating value, while the others can respond to it.

Irrespective of which participant acts as a trigger, for **all other** actuators, the *Send highest actuating value* parameter must be set to the default value of *Only if own actuating value is greater*.

6.8.4 Actuating value dependent pump control

The common flow pump should only be switched on when at least 1 valve is actually open. Otherwise it is switched off.

This is implemented with the help of the *Highest actuating value* objects.

Example:

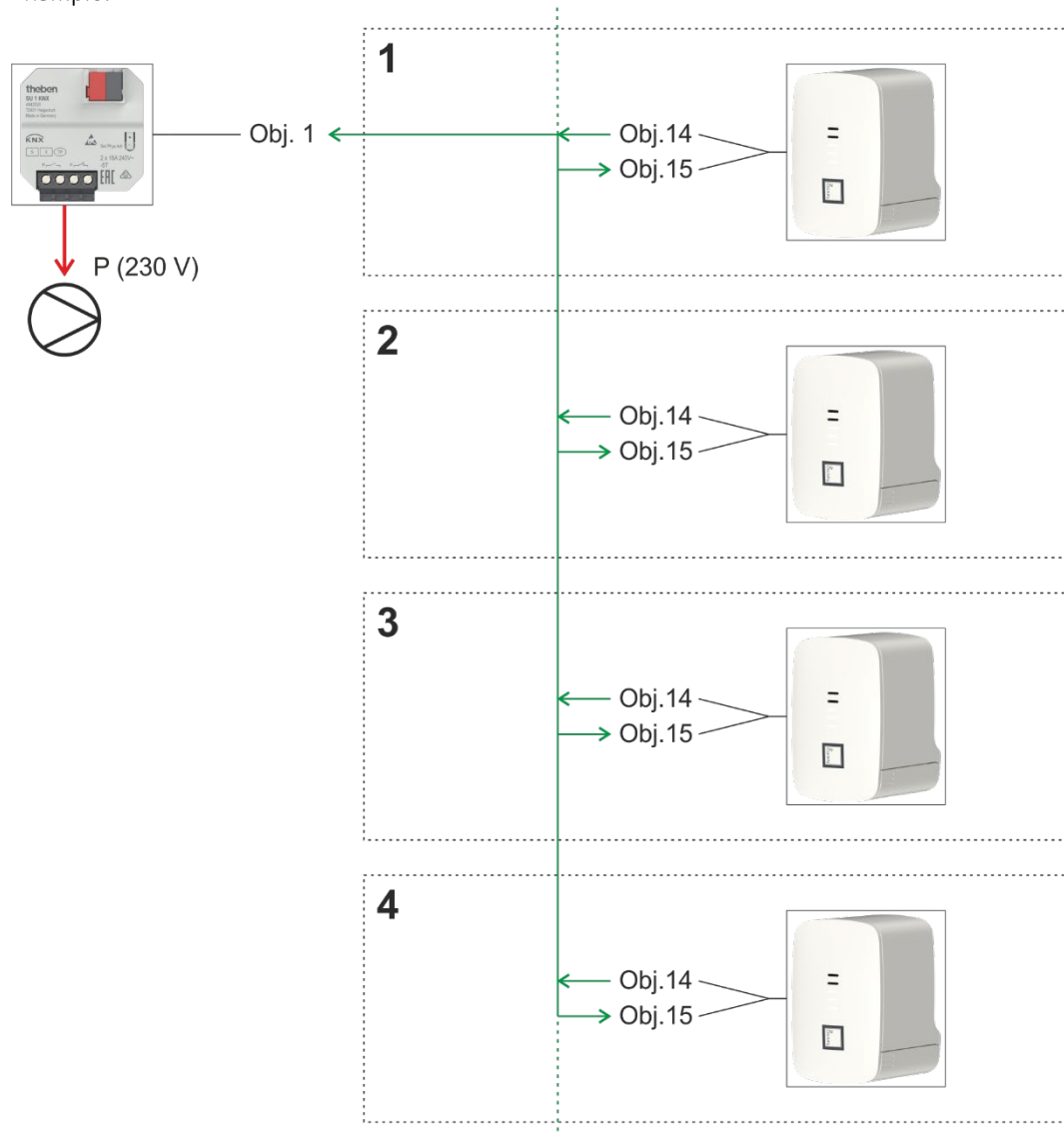

The KNX Electromotor Valve Control controller in zone 1 sends its current valve position (e.g. 10%) cyclically to the group address *Highest actuating value*.

All other devices receive it and compare it with their own position.

If the own position is lower, no telegram is sent.

If a device has a higher actuating value, it will be sent to this group address as the new highest actuating value.

Result:

If all valves are closed, the highest actuating value is = 0%

If a valve is open, the highest actuating value is > 0%

Switch actuator:

If this group address is assigned to a threshold input of the switch actuator, the pump control is ready.

The switch actuator channel must be configured as a threshold input for percentage values. With a threshold and a hysteresis of 1%, the pump switches on if required and switches off again as soon as the last valve is completely closed.

6.9 Restriction of actuating value

This setting determines how far the valve should be maximally opened or closed.

6.9.1 Application:

To prevent the valve from whistling in the lower actuating value range, the minimum actuating value can be limited to e.g. 5%.

A valve that has the same flow rate between 90% and 100% can be restricted to 90%.

The response to actuating values outside the restrictions can be set with the parameter *Actuating value when value violates the min./max. actuating value*.

6.9.2 Example

Minimum actuating value = 5%

Maximum actuating value = 90%

Parameter <i>Actuating value when value violates the min./max. actuating value:</i>	Valve position with actuating value		
	0%	below 5%	above 90%
<i>0% or 100%</i>	0%	0%	100%
<i>Use set actuating values</i>	5%	5%	90%
<i>0 = 0%, otherwise use set actuating values</i>	0%	5%	90%
<i>< min. actuating val. = 0%, otherwise scale</i>	0%	0% ⁴¹	100% ⁴²

i With the setting *< min act. value. = 0%, otherwise scale* the range between minimum and maximum actuating value is considered a virtual 100% setting range.
 With a required actuating value of 50% (in our example), the valve is positioned in the middle of the range 5-90%, i.e. at 53%.

⁴¹ Actual mechanical position corresponds to the minimum actuating value (5%)

⁴² Actual mechanical position corresponds to the maximum actuating value (90%)

6.10 PWM cycle

6.10.1 Basic principle

In order to achieve e.g. a heating output of 50%, the 50% actuating value is converted into switch-on/switch-off cycles.

The actuator is switched on for 50% of the time and switched off for 50% of the time over a fixed period (10 minutes in our example).

Example: 2 different turn-on times of 2 and 7 minutes indicate the implementation of 2 different actuating values, that is once 20% and once 70% during a PWM period of 10 minutes.

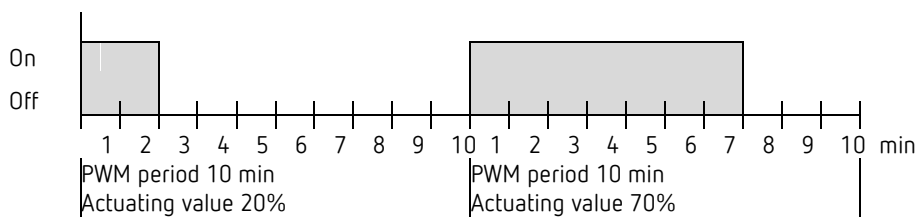

6.10.2 Response to changes in the actuating value

Every change in the actuating value is immediately transferred to the PWM cycle, in order to respond to changes in the quickest possible time.

Example 1:

The last actuating value was 20% (A).

A new actuating value of 50% is received during the cycle (B).

The output is immediately switched on and the missing 30% turn-on time is added.

The next cycle is executed with 50% (C).

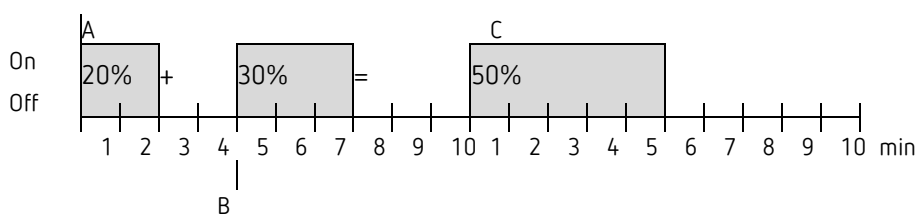

If the rated turn-on time for the current cycle has already been exceeded while receiving the new actuating value, the output is immediately switched off and the new actuating value is executed during the next cycle.

Example 2:

The last actuating value was 50% (A)

A new actuating value of 30% is received during the cycle (B).

The output is switched off after completing 30% of the PWM cycle and thus the new actuating value is already executed.

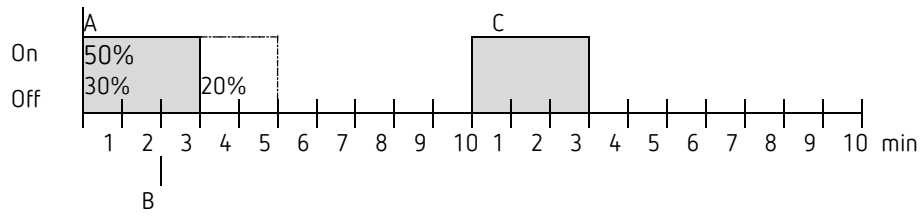

6.11 Setpoint calculation

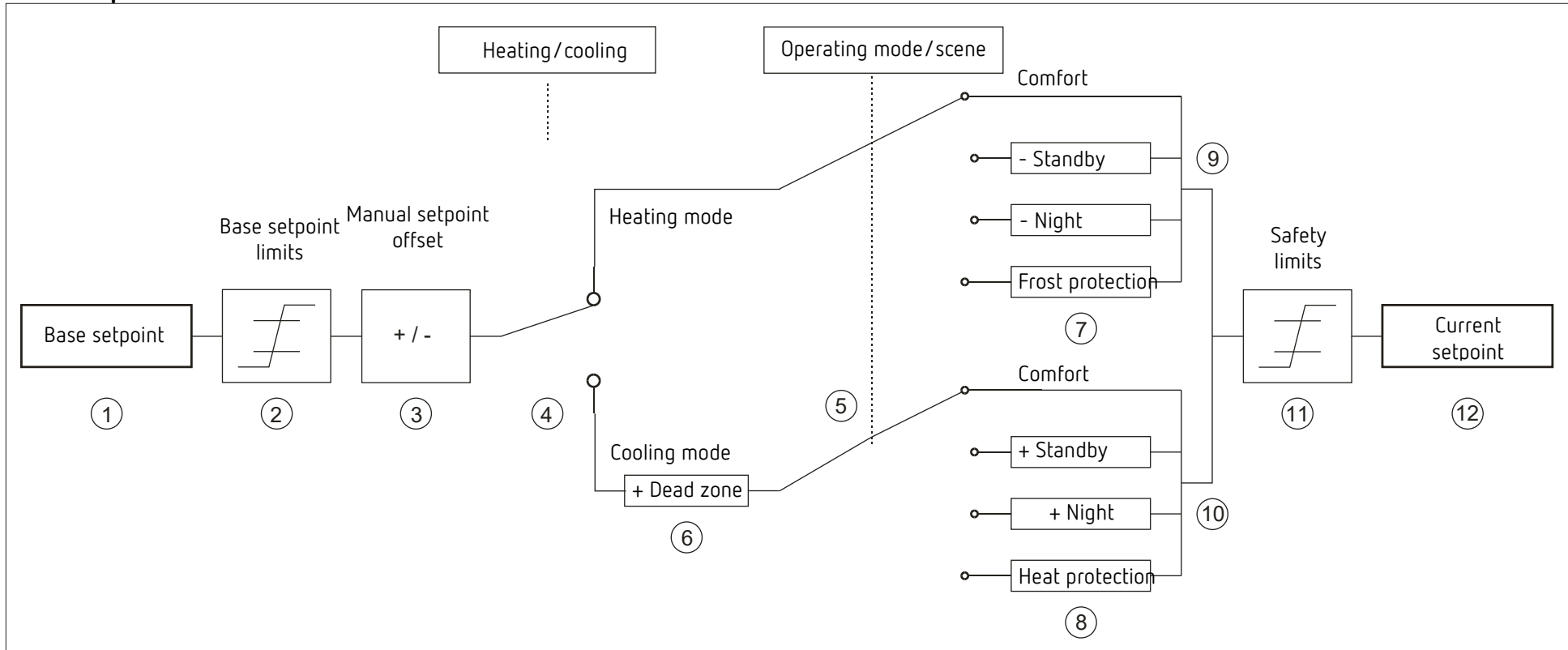

- 1 Preset base setpoint
- 2 Max. and min. valid base setpoints
- 3 Manual setpoint offset
- 4 Change between heating and cooling: Automatically or via object
- 5 Selection of operating mode by object
- 6 In cooling mode, the setpoint is increased by the amount of the dead zone

- 7 The setpoint is replaced by the setpoint for frost protection mode
- 8 The setpoint is replaced by the setpoint for heat protection mode
- 9 Setpoint after reductions caused by the operating mode
- 10 Setpoint after increases caused by the operating mode
- 11 The limits for frost and heat protection must be adhered to
- 12 Current setpoint after increases, reductions and limits caused by the operation